

High Speed CMOS Logic 4-Bit Parallel Access Register

Features

- Asynchronous Master Reset
- J, \bar{K} , (D) Inputs to First Stage
- Fully Synchronous Serial or Parallel Data Transfer
- Shift Right and Parallel Load Capability
- Complementary Output From Last Stage
- Buffered Inputs
- Typical $f_{MAX} = 50\text{MHz}$ at $V_{CC} = 5\text{V}$,
 $C_L = 15\text{pF}$, $T_A = 25^\circ\text{C}$
- Fanout (Over Temperature Range)
 - Standard Outputs 10 LSTTL Loads
 - Bus Driver Outputs 15 LSTTL Loads
- Wide Operating Temperature Range . . . -55°C to 125°C
- Balanced Propagation Delay and Transition Times
- Significant Power Reduction Compared to LSTTL Logic ICs
- HC Types
 - 2V to 6V Operation
 - High Noise Immunity: $N_{IL} = 30\%$, $N_{IH} = 30\%$ of V_{CC} at $V_{CC} = 5\text{V}$

Description

The device is useful in a wide variety of shifting, counting and storage applications. It performs serial, parallel, serial to parallel, or parallel to serial data transfers at very high speeds.

The two modes of operation, shift right (Q_0 - Q_1) and parallel load, are controlled by the state of the Parallel Enable (\bar{PE}) input. Serial data enters the first flip-flop (Q_0) via the J and \bar{K} inputs when the \bar{PE} input is high, and is shifted one bit in the direction Q_0 - Q_1 - Q_2 - Q_3 following each Low to High clock transition. The J and K inputs provide the flexibility of the JK-type input for special applications and by tying the two pins together, the simple D-type input for general applications. The device appears as four common-clocked D flip-flops when the \bar{PE} input is Low. After the Low to High clock transition, data on the parallel inputs (D0-D3) is transferred to the respective Q_0 - Q_3 outputs. Shift left operation (Q_3 - Q_2) can be achieved by tying the Q_n outputs to the D_{n-1} inputs and holding the \bar{PE} input low.

All parallel and serial data transfers are synchronous, occurring after each Low to High clock transition. The 'HC195 series utilizes edge triggering; therefore, there is no restriction on the activity of the J, K, Pn and \bar{PE} inputs for logic operations, other than set-up and hold time requirements. A Low on the asynchronous Master Reset (\bar{MR}) input sets all Q outputs Low, independent of any other input condition.

Ordering Information

PART NUMBER	TEMP. RANGE (°C)	PACKAGE
CD54HC195F3A	-55 to 125	16 Ld CERDIP
CD74HC195E	-55 to 125	16 Ld PDIP
CD74HC195M	-55 to 125	16 Ld SOIC
CD74HC195NSR	-55 to 125	16 Ld SOP

NOTES:

1. When ordering, use the entire part number.
2. Die for this part number is available which meets all electrical specifications. Please contact your local TI sales office or customer service for ordering information.

Pinout

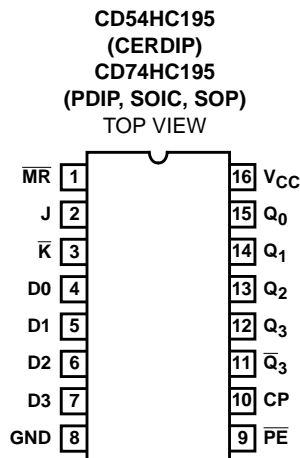

Functional Diagram

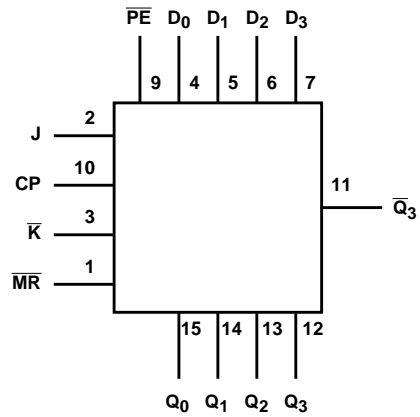

TRUTH TABLE

OPERATING MODES	INPUTS						OUTPUT				
	\overline{MR}	CP	\overline{PE}	J	\overline{K}	D _n	Q ₀	Q ₁	Q ₂	Q ₃	\overline{Q}_3
Asynchronous Reset	L	X	X	X	X	X	L	L	L	L	H
Shift, Set First Stage	H	↑	h	h	h	X	H	q ₀	q ₁	q ₂	\overline{q}_2
Shift, Reset First Stage	H	↑	h	l	l	X	L	q ₀	q ₁	q ₂	\overline{q}_2
Shift, Toggle First Stage	H	↑	h	h	l	X	\overline{q}_0	q ₀	q ₁	q ₂	\overline{q}_2
Shift, Retain First Stage	H	↑	h	l	h	X	q ₀	q ₀	q ₁	q ₂	\overline{q}_2
Parallel Load	H	↑	l	X	X	d _n	d ₀	d ₁	d ₂	d ₃	\overline{d}_2

NOTE: H = High Voltage Level
 L = Low Voltage Level,
 X = Don't Care
 ↑ = Transition from Low to High Level
 l = Low Voltage Level One Set-up Time Prior to the Low to High Clock Transition
 h = Low Voltage Level One Set-up Time prior to the High to Low Clock Transition,
 d_n (q_n) = Lower Case Letters Indicate the State of the Referenced Input (or output) One Set-up Time Prior to the Low to High Clock Transition.

CD54/74HC195

Absolute Maximum Ratings

DC Supply Voltage, V_{CC}	-0.5V to 7V
DC Input Diode Current, I_{IK}	
For $V_I < -0.5V$ or $V_I > V_{CC} + 0.5V$	$\pm 20mA$
DC Output Diode Current, I_{OK}	
For $V_O < -0.5V$ or $V_O > V_{CC} + 0.5V$	$\pm 20mA$
DC Output Source or Sink Current per Output Pin, I_O	
For $V_O > -0.5V$ or $V_O < V_{CC} + 0.5V$	$\pm 25mA$
DC V_{CC} or Ground Current, I_{CC} or I_{GND}	$\pm 50mA$

Thermal Information

Package Thermal Impedance, θ_{JA} (see Note 3):	
PDIP Package	67°C/W
SOIC Package	73°C/W
SOP Package	64°C/W
Maximum Junction Temperature	150°C
Maximum Storage Temperature Range	-65°C to 150°C
Maximum Lead Temperature (Soldering 10s)	300°C
(SOIC - Lead Tips Only)	

Operating Conditions

Temperature Range (T_A)	-55°C to 125°C
Supply Voltage Range, V_{CC}	
HC Types2V to 6V
HCT Types4.5V to 5.5V
DC Input or Output Voltage, V_I, V_O	0V to V_{CC}
Input Rise and Fall Time	
2V	1000ns (Max)
4.5V	500ns (Max)
6V	400ns (Max)

CAUTION: Stresses above those listed in "Absolute Maximum Ratings" may cause permanent damage to the device. This is a stress only rating and operation of the device at these or any other conditions above those indicated in the operational sections of this specification is not implied.

NOTE:

- The package thermal impedance is calculated in accordance with JESD 51-7.

DC Electrical Specifications

PARAMETER	SYMBOL	TEST CONDITIONS		V_{CC} (V)	25°C			-40°C TO 85°C		-55°C TO 125°C		UNITS
		V_I (V)	I_O (mA)		MIN	TYP	MAX	MIN	MAX	MIN	MAX	
High Level Input Voltage	V_{IH}	-	-	2	1.5	-	-	1.5	-	1.5	-	V
				4.5	3.15	-	-	3.15	-	3.15	-	V
				6	4.2	-	-	4.2	-	4.2	-	V
Low Level Input Voltage	V_{IL}	-	-	2	-	-	0.5	-	0.5	-	0.5	V
				4.5	-	-	1.35	-	1.35	-	1.35	V
				6	-	-	1.8	-	1.8	-	1.8	V
High Level Output Voltage CMOS Loads	V_{OH}	V_{IH} or V_{IL}	-0.02	2	1.9	-	-	1.9	-	1.9	-	V
				4.5	4.4	-	-	4.4	-	4.4	-	V
				6	5.9	-	-	5.9	-	5.9	-	V
High Level Output Voltage TTL Loads	V_{OH}	V_{IH} or V_{IL}	-	-	-	-	-	-	-	-	-	V
				4.5	3.98	-	-	3.84	-	3.7	-	V
				6	5.48	-	-	5.34	-	5.2	-	V
Low Level Output Voltage CMOS Loads	V_{OL}	V_{IH} or V_{IL}	0.02	2	-	-	0.1	-	0.1	-	0.1	V
				4.5	-	-	0.1	-	0.1	-	0.1	V
				6	-	-	0.1	-	0.1	-	0.1	V
Low Level Output Voltage TTL Loads	V_{OL}	V_{IH} or V_{IL}	-	-	-	-	-	-	-	-	-	V
				4.5	-	-	0.26	-	0.33	-	0.4	V
				6	-	-	0.26	-	0.33	-	0.4	V
Input Leakage Current	I_I	V_{CC} or GND	-	6	-	-	± 0.1	-	± 1	-	± 1	μA
Quiescent Device Current (Note)	I_{CC}	V_{CC} or GND	0	6	-	-	8	-	80	-	160	μA

NOTE: For dual-supply systems theoretical worst case ($V_I = 2.4V, V_{CC} = 5.5V$) specification is 1.8mA.

CD54/74HC195

Prerequisite For Switching Function

PARAMETER	SYMBOL	TEST CONDITIONS	V _{CC} (V)	25°C		-40°C TO 85°C		-55°C TO 125°C		UNITS
				MIN	MAX	MIN	MAX	MIN	MAX	
Clock Frequency	f _{MAX}	-	2	6	-	5	-	4	-	MHz
			4.5	30	-	25	-	20	-	MHz
			6	35	-	29	-	23	-	MHz
MR Pulse Width	t _w	-	2	80	-	100	-	120	-	ns
			4.5	16	-	20	-	24	-	ns
			6	14	-	17	-	20	-	ns
Clock Pulse Width	t _w	-	2	80	-	100	-	120	-	ns
			4.5	16	-	20	-	24	-	ns
			6	14	-	17	-	20	-	ns
Set-up Time J, K, PE to Clock	t _{SU}	-	2	100	-	125	-	150	-	ns
			4.5	20	-	25	-	30	-	ns
			6	17	-	21	-	26	-	ns
Hold Time J, K, PE to Clock	t _H	-	2	3	-	3	-	3	-	ns
			4.5	3	-	3	-	3	-	ns
			6	5	-	3	-	3	-	ns
Removal Time, MR to Clock	t _{REM}	-	2	80	-	100	-	120	-	ns
			4.5	16	-	20	-	24	-	ns
			6	14	-	17	-	20	-	ns

Switching Specifications Input t_r, t_f = 6ns

PARAMETER	SYMBOL	TEST CONDITIONS	V _{CC} (V)	25°C		-40°C TO 85°C	-55°C TO 125°C	UNITS
				TYP	MAX	MAX	MAX	
HC TYPES								
Propagation Delay, CP to Output	t _{PLH} , t _{PHL}	C _L = 50pF	2	-	175	220	265	ns
			4.5	-	35	44	53	ns
			6	-	30	37	45	ns
Propagation Delay, MR to Output	t _{PLH} , t _{PHL}	C _L = 50pF	2	-	150	190	225	ns
			4.5	-	30	38	45	ns
			6	-	26	33	38	ns
Output Transition Times (Figure 1)	t _{TLH} , t _{THL}	C _L = 50pF	2	-	75	95	110	ns
			4.5	-	15	19	22	ns
			6	-	13	16	19	ns
Input Capacitance	C _{IN}	-	-	-	10	10	10	pF
CP to Q _n Propagation Delay	t _{PLH} , t _{PHL}	C _L = 15pF	5	14	-	-	-	ns
MR to Q _n	t _{PHL}	C _L = 15pF	5	13	-	-	-	ns
Maximum Clock Frequency	f _{MAX}	C _L = 15pF	5	50	-	-	-	MHz
Power Dissipation Capacitance (Notes 4, 5)	C _{PD}	C _L = 15pF		45	-	-	-	pF

NOTES:

4. C_{PD} is used to determine the dynamic power consumption, per flip-flop.
5. P_D = V_{CC}² f_i + Σ (C_L V_{CC}² + f_O) where f_i = Input Frequency, f_O = Output Frequency, C_L = Output Load Capacitance, V_{CC} = Supply Voltage.

Test Circuit and Waveforms

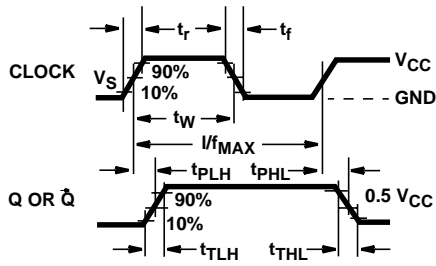

FIGURE 1. CLOCK PRE-REQUISITE AND PROPAGATION DELAYS AND OUTPUT TRANSITION TIMES

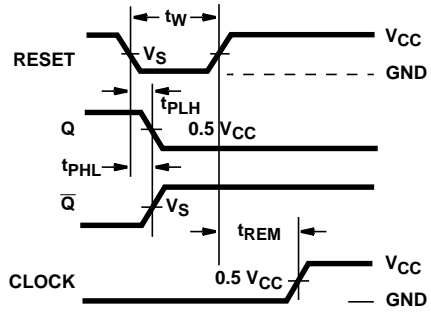

FIGURE 2. MASTER RESET PRE-REQUISITE AND PROPAGATION DELAYS

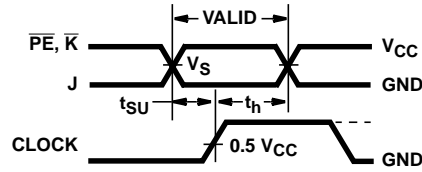

FIGURE 3. J, \bar{K} OR PARALLEL ENABLE PRE-REQUISITE TIMES