

SN74LS122 SN74LS123

Retriggerable Monostable Multivibrators

These dc triggered multivibrators feature pulse width control by three methods. The basic pulse width is programmed by selection of external resistance and capacitance values. The LS122 has an internal timing resistor that allows the circuits to be used with only an external capacitor. Once triggered, the basic pulse width may be extended by retriggering the gated low-level-active (A) or high-level-active (B) inputs, or be reduced by use of the overriding clear.

- Overriding Clear Terminates Output Pulse
- Compensated for V_{CC} and Temperature Variations
- DC Triggered from Active-High or Active-Low Gated Logic Inputs
- Retriggerable for Very Long Output Pulses, up to 100% Duty Cycle
- Internal Timing Resistors on LS122

GUARANTEED OPERATING RANGES

| Symbol | Parameter | Min | Typ | Max | Unit |
|-------------------|--|----------------|-----|------|------------|
| V_{CC} | Supply Voltage | 4.75 | 5.0 | 5.25 | V |
| T_A | Operating Ambient Temperature Range | 0 | 25 | 70 | °C |
| I_{OH} | Output Current – High | | | -0.4 | mA |
| I_{OL} | Output Current – Low | | | 8.0 | mA |
| R_{ext} | External Timing Resistance | 5.0 | | 260 | k Ω |
| C_{ext} | External Capacitance | No Restriction | | | |
| R_{ext}/C_{ext} | Wiring Capacitance at R_{ext}/C_{ext} Terminal | | | 50 | pF |



ON Semiconductor
Formerly a Division of Motorola
<http://onsemi.com>

LOW POWER SCHOTTKY

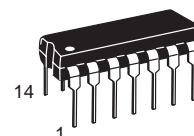

PLASTIC
N SUFFIX
CASE 646

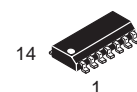

SOIC
D SUFFIX
CASE 751A

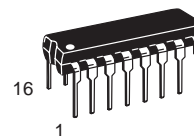

PLASTIC
N SUFFIX
CASE 648

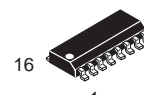

SOIC
D SUFFIX
CASE 751B

ORDERING INFORMATION

| Device | Package | Shipping |
|------------|------------|------------------|
| SN74LS122N | 14 Pin DIP | 2000 Units/Box |
| SN74LS122D | 14 Pin | 2500/Tape & Reel |
| SN74LS123N | 16 Pin DIP | 2000 Units/Box |
| SN74LS123D | 16 Pin | 2500/Tape & Reel |

SN74LS122 SN74LS123

SN74LS123 (TOP VIEW)
(SEE NOTES 1 THRU 4)

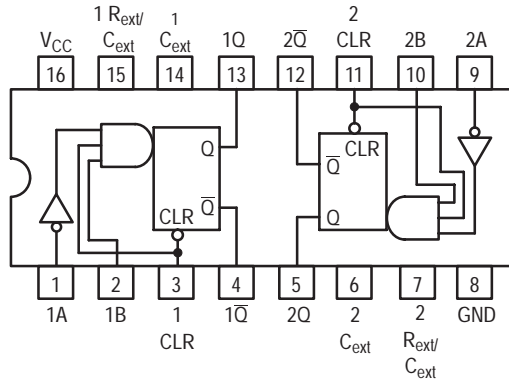

SN74LS122 (TOP VIEW)
(SEE NOTES 1 THRU 4)

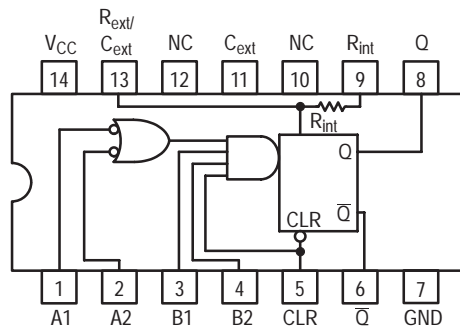

NC — NO INTERNAL CONNECTION.

NOTES:

1. An external timing capacitor may be connected between C_{ext} and R_{ext}/C_{ext} (positive).
2. To use the internal timing resistor of the LS122, connect R_{int} to V_{CC} .
3. For improved pulse width accuracy connect an external resistor between R_{ext}/C_{ext} and V_{CC} with R_{int} open-circuited.
4. To obtain variable pulse widths, connect an external variable resistance between R_{int}/C_{ext} and V_{CC} .

SN74LS122 SN74LS123

LS122 FUNCTIONAL TABLE

| INPUTS | | | | OUTPUTS | | |
|--------|----|----|----|---------|---|-----------|
| CLEAR | A1 | A2 | B1 | B2 | Q | \bar{Q} |
| L | X | X | X | X | L | H |
| X | H | H | X | X | L | H |
| X | X | X | L | X | L | H |
| X | X | X | X | L | L | H |
| H | L | X | ↑ | H | | |
| H | L | X | H | ↑ | | |
| H | X | L | ↑ | H | | |
| H | X | L | H | ↑ | | |
| H | H | ↓ | H | H | | |
| H | ↓ | ↓ | H | H | | |
| H | ↓ | H | H | H | | |
| ↑ | L | X | H | H | | |
| ↑ | X | L | H | H | | |

LS123 FUNCTIONAL TABLE

| INPUTS | | | OUTPUTS | |
|--------|---|---|---------|-----------|
| CLEAR | A | B | Q | \bar{Q} |
| L | X | X | L | H |
| X | H | X | L | H |
| X | X | L | L | H |
| H | L | ↑ | | |
| H | ↓ | H | | |
| ↑ | L | H | | |

TYPICAL APPLICATION DATA

The output pulse t_W is a function of the external components, C_{ext} and R_{ext} or C_{ext} and R_{int} on the LS122. For values of $C_{ext} \geq 1000$ pF, the output pulse at $V_{CC} = 5.0$ V and $V_{RC} = 5.0$ V (see Figures 1, 2, and 3) is given by

$$t_W = K R_{ext} C_{ext} \text{ where } K \text{ is nominally } 0.45$$

If C_{ext} is in pF and R_{ext} is in $k\Omega$ then t_W is in nanoseconds.

The C_{ext} terminal of the LS122 and LS123 is an internal connection to ground, however for the best system performance C_{ext} should be hard-wired to ground.

Care should be taken to keep R_{ext} and C_{ext} as close to the monostable as possible with a minimum amount of inductance between the R_{ext}/C_{ext} junction and the R_{ext}/C_{ext} pin. Good groundplane and adequate bypassing should be designed into the system for optimum performance to ensure that no false triggering occurs.

It should be noted that the C_{ext} pin is internally connected to ground on the LS122 and LS123, but not on the LS221. Therefore, if C_{ext} is hard-wired externally to ground, substitution of a LS221 onto a LS123 socket will cause the LS221 to become non-functional.

The switching diode is not needed for electrolytic capacitance application and should not be used on the LS122 and LS123.

To find the value of K for $C_{ext} \geq 1000$ pF, refer to Figure 4. Variations on V_{CC} or V_{RC} can cause the value of K to change, as can the temperature of the LS123, LS122.

Figures 5 and 6 show the behavior of the circuit shown in Figures 1 and 2 if separate power supplies are used for V_{CC} and V_{RC} . If V_{CC} is tied to V_{RC} , Figure 7 shows how K will vary with V_{CC} and temperature. Remember, the changes in R_{ext} and C_{ext} with temperature are not calculated and included in the graph.

As long as $C_{ext} \geq 1000$ pF and $5K \leq R_{ext} \leq 260K$, the change in K with respect to R_{ext} is negligible.

If $C_{ext} \leq 1000$ pF the graph shown on Figure 8 can be used to determine the output pulse width. Figure 9 shows how K will change for $C_{ext} \leq 1000$ pF if V_{CC} and V_{RC} are connected to the same power supply. The pulse width t_W in nanoseconds is approximated by

$$t_W = 6 + 0.05 C_{ext} (\text{pF}) + 0.45 R_{ext} (k\Omega) C_{ext} + 11.6 R_{ext}$$

In order to trim the output pulse width, it is necessary to include a variable resistor between V_{CC} and the R_{ext}/C_{ext} pin or between V_{CC} and the R_{ext} pin of the LS122. Figure 10, 11, and 12 show how this can be done. R_{ext} remote should be kept as close to the monostable as possible.

Retriggering of the part, as shown in Figure 3, must not occur before C_{ext} is discharged or the retrigger pulse will not have any effect. The discharge time of C_{ext} in nanoseconds is guaranteed to be less than $0.22 C_{ext}$ (pF) and is typically $0.05 C_{ext}$ (pF).

For the smallest possible deviation in output pulse widths from various devices, it is suggested that C_{ext} be kept ≥ 1000 pF.

SN74LS122 SN74LS123

WAVEFORMS

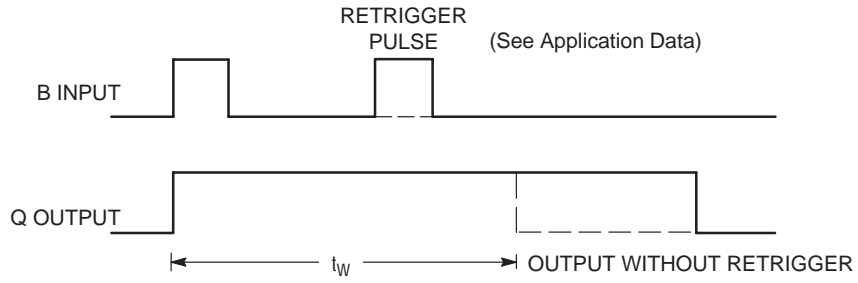

EXTENDING PULSE WIDTH

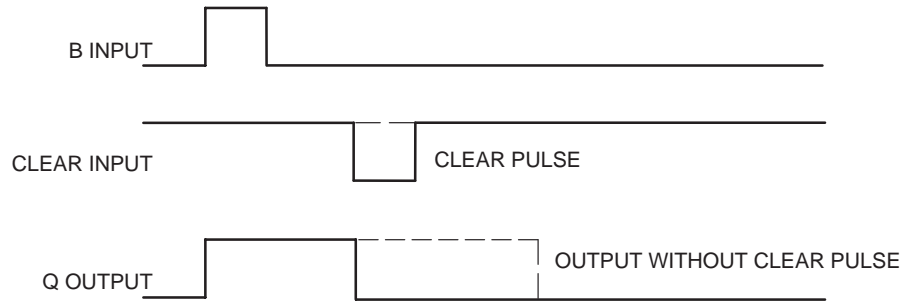

OVERRIDING THE OUTPUT PULSE

SN74LS122 SN74LS123

DC CHARACTERISTICS OVER OPERATING TEMPERATURE RANGE (unless otherwise specified)

| Symbol | Parameter | Limits | | | Unit | Test Conditions |
|-----------------|--------------------------------|--------|-------|------|------|---|
| | | Min | Typ | Max | | |
| V _{IH} | Input HIGH Voltage | 2.0 | | | V | Guaranteed Input HIGH Voltage for All Inputs |
| V _{IL} | Input LOW Voltage | | | 0.8 | V | Guaranteed Input LOW Voltage for All Inputs |
| V _{IK} | Input Clamp Diode Voltage | | -0.65 | -1.5 | V | V _{CC} = MIN, I _{IN} = -18 mA |
| V _{OH} | Output HIGH Voltage | 2.7 | 3.5 | | V | V _{CC} = MIN, I _{OH} = MAX, V _{IN} = V _{IH} or V _{IL} per Truth Table |
| V _{OL} | Output LOW Voltage | | 0.25 | 0.4 | V | I _{OL} = 4.0 mA V _{CC} = V _{CC} MIN, V _{IN} = V _{IL} or V _{IH} per Truth Table |
| | | | 0.35 | 0.5 | V | |
| I _{IH} | Input HIGH Current | | | 20 | μA | V _{CC} = MAX, V _{IN} = 2.7 V |
| | | | | 0.1 | mA | V _{CC} = MAX, V _{IN} = 7.0 V |
| I _{IL} | Input LOW Current | | | -0.4 | mA | V _{CC} = MAX, V _{IN} = 0.4 V |
| I _{OS} | Short Circuit Current (Note 1) | -20 | | -100 | mA | V _{CC} = MAX |
| I _{CC} | Power Supply Current | LS122 | | 11 | mA | V _{CC} = MAX |
| | | LS123 | | 20 | | |

Note 1: Not more than one output should be shorted at a time, nor for more than 1 second.

AC CHARACTERISTICS (T_A = 25°C, V_{CC} = 5.0 V)

| Symbol | Parameter | Limits | | | Unit | Test Conditions |
|--------------------------------------|--|--------|----------|----------|------|--|
| | | Min | Typ | Max | | |
| t _{PLH} t _{PHL} | Propagation Delay, A to Q Propagation Delay, A to \bar{Q} | | 23 32 | 33 45 | ns | C _{ext} = 0 C _L = 15 pF R _{ext} = 5.0 kΩ R _L = 2.0 kΩ |
| t _{PLH} t _{PHL} | Propagation Delay, B to Q Propagation Delay, B to \bar{Q} | | 23 34 | 44 56 | | |
| t _{PLH} t _{PHL} | Propagation Delay, Clear to \bar{Q} Propagation Delay, Clear to Q | | 28 | 45 | ns | |
| | | | 20 | 27 | | |
| t _{W min} | A or B to Q | | 116 | 200 | ns | C _{ext} = 1000 pF, R _{ext} = 10 kΩ, C _L = 15 pF, R _L = 2.0 kΩ |
| t _{WQ} | A to B to Q | 4.0 | 4.5 | 5.0 | μs | |

AC SETUP REQUIREMENTS (T_A = 25°C, V_{CC} = 5.0 V)

| Symbol | Parameter | Limits | | | Unit | Test Conditions |
|----------------|-------------|--------|-----|-----|------|-----------------|
| | | Min | Typ | Max | | |
| t _W | Pulse Width | 40 | | | ns | |

SN74LS122 SN74LS123

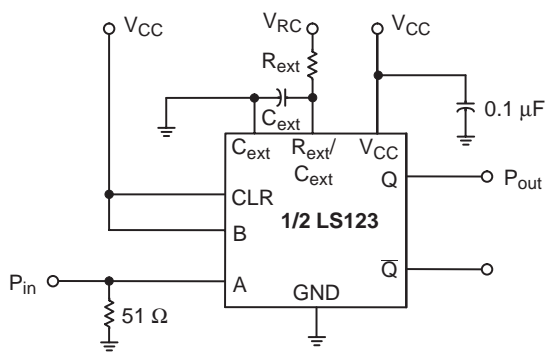

Figure 1.

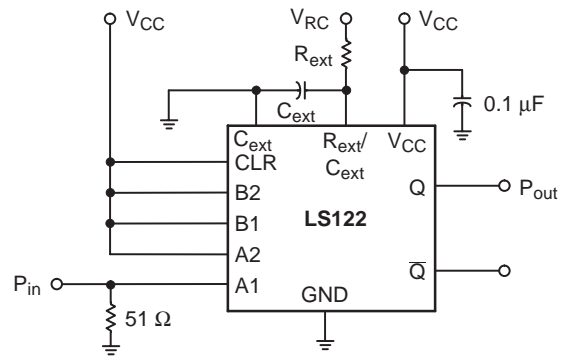

Figure 2.

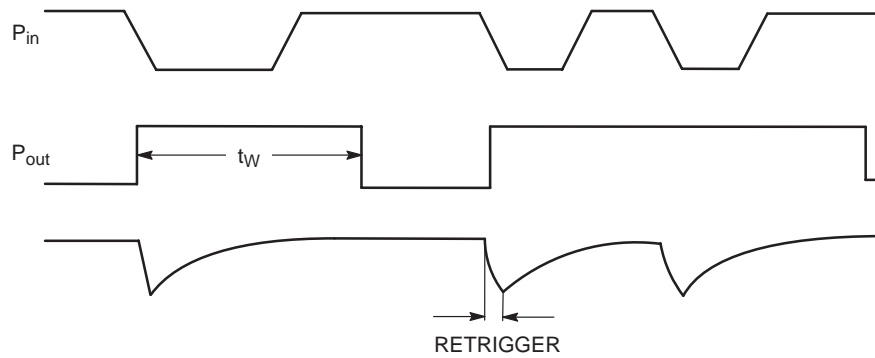

Figure 3.

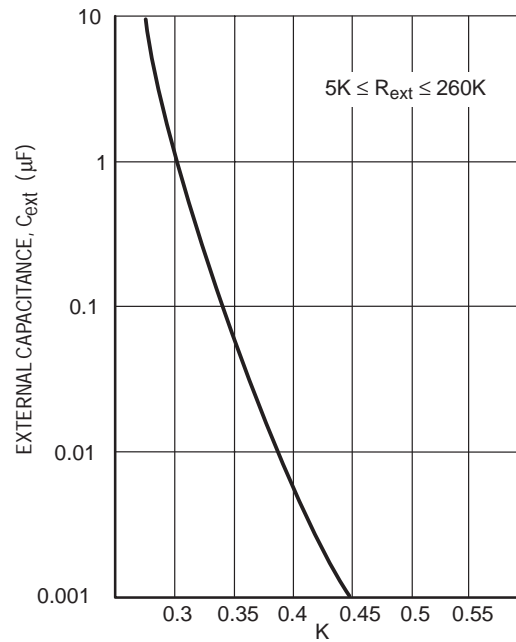

Figure 4.

SN74LS122 SN74LS123

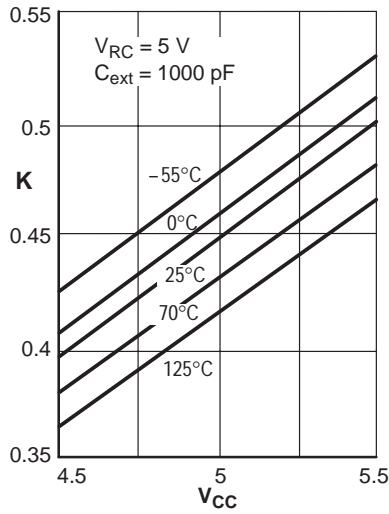

Figure 5. K versus V_{CC}

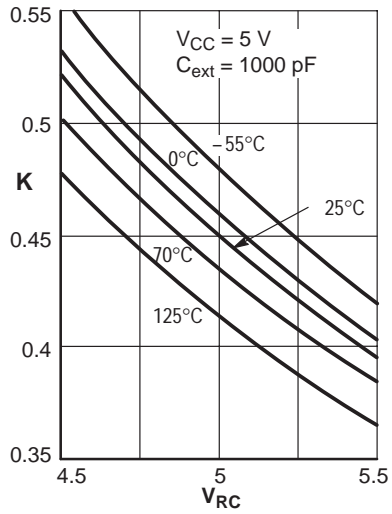

Figure 6. K versus V_{RC}

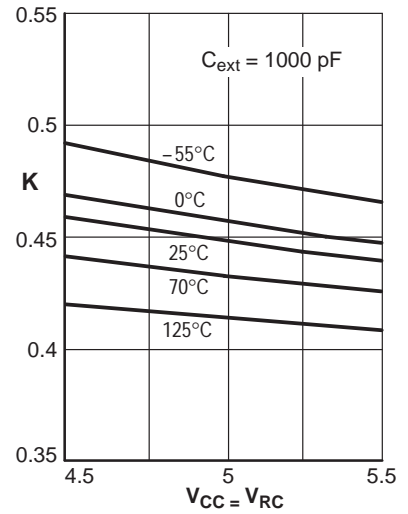

Figure 7. K versus V_{CC} and V_{RC}

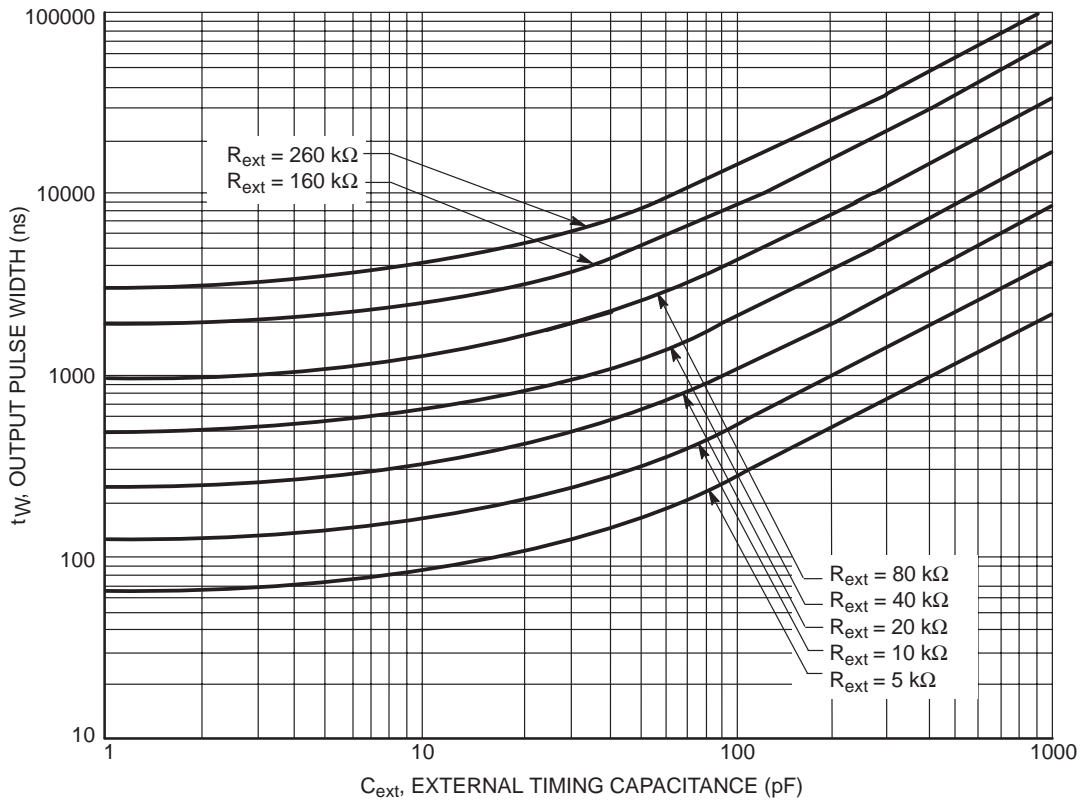

Figure 8.

SN74LS122 SN74LS123

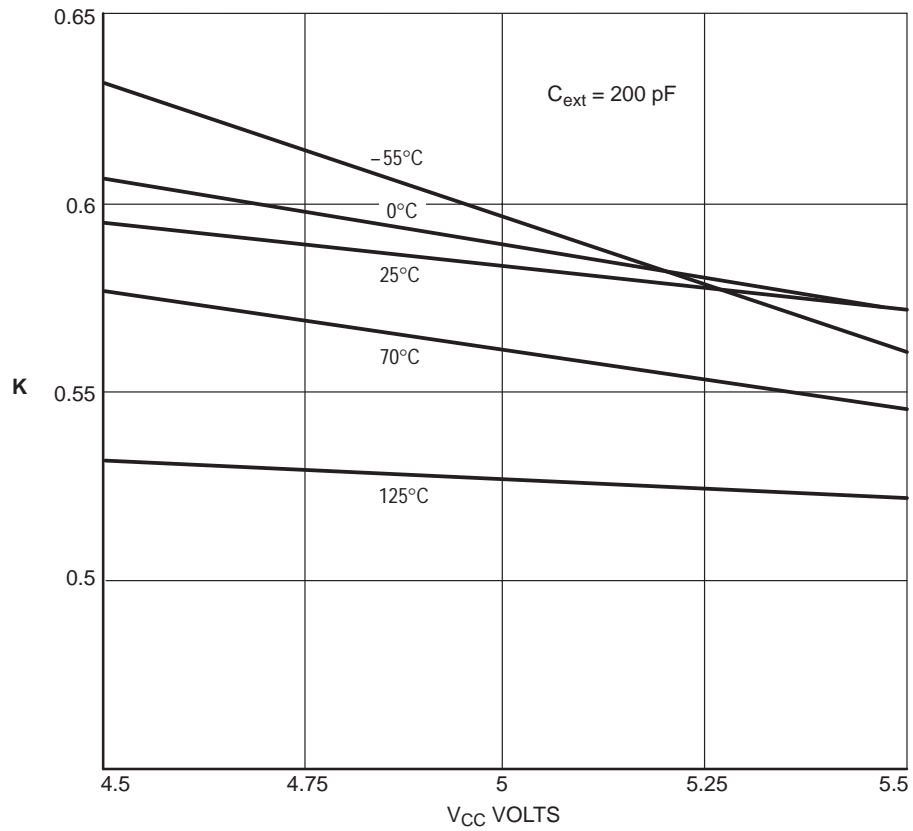

Figure 9.

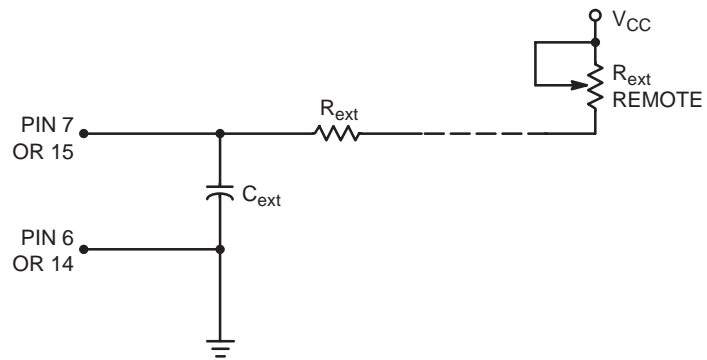

Figure 10. LS123 Remote Trimming Circuit

SN74LS122 SN74LS123

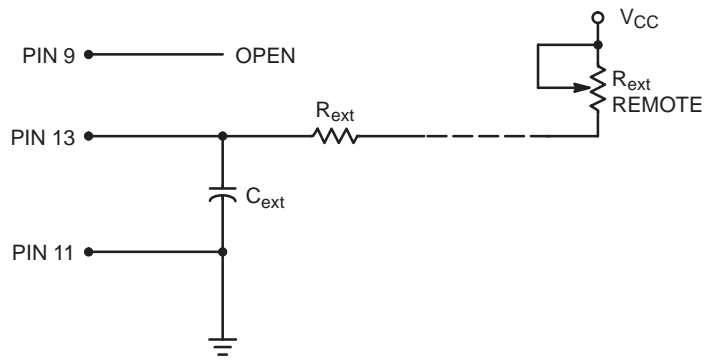

Figure 11. LS122 Remote Trimming Circuit Without R_{ext}

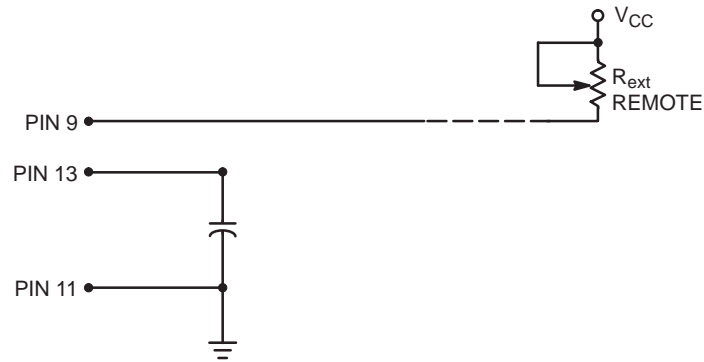

Figure 12. LS122 Remote Trimming Circuit with R_{int}