

SN74LS125A SN74LS126A

Quad 3-State Buffers



ON Semiconductor
Formerly a Division of Motorola
<http://onsemi.com>

**LOW
POWER
SCHOTTKY**

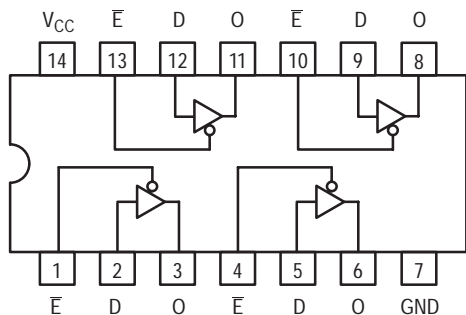

LS125A

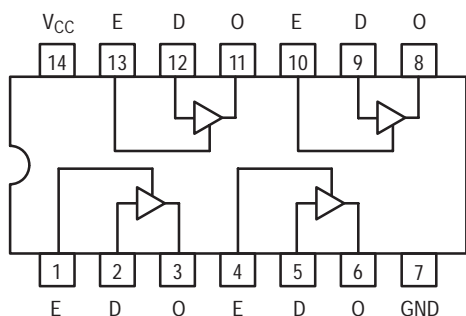

LS126A

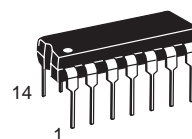

**PLASTIC
N SUFFIX
CASE 646**

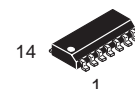

**SOIC
D SUFFIX
CASE 751A**

TRUTH TABLES

LS125A

INPUTS		OUTPUT
E	D	
L	L	L
L	H	H
H	X	(Z)

LS126A

INPUTS		OUTPUT
E	D	
H	L	L
H	H	H
L	X	(Z)

L = LOW Voltage Level
H = HIGH Voltage Level
X = Don't Care
(Z) = High Impedance (off)

GUARANTEED OPERATING RANGES

Symbol	Parameter	Min	Typ	Max	Unit
V _{CC}	Supply Voltage	4.75	5.0	5.25	V
T _A	Operating Ambient Temperature Range	0	25	70	°C
I _{OH}	Output Current – High			-2.6	mA
I _{OL}	Output Current – Low			24	mA

ORDERING INFORMATION

Device	Package	Shipping
SN74LS125AN	14 Pin DIP	2000 Units/Box
SN74LS125AD	14 Pin	2500/Tape & Reel
SN74LS126AN	14 Pin DIP	2000 Units/Box
SN74LS126AD	14 Pin	2500/Tape & Reel

SN74LS125A SN74LS126A

DC CHARACTERISTICS OVER OPERATING TEMPERATURE RANGE (unless otherwise specified)

Symbol	Parameter	Limits			Unit	Test Conditions	
		Min	Typ	Max			
V _{IH}	Input HIGH Voltage	2.0			V	Guaranteed Input HIGH Voltage for All Inputs	
V _{IL}	Input LOW Voltage			0.8	V	Guaranteed Input LOW Voltage for All Inputs	
V _{IK}	Input Clamp Diode Voltage		-0.65	-1.5	V	V _{CC} = MIN, I _{IN} = -18 mA	
V _{OH}	Output HIGH Voltage	2.4			V	V _{CC} = MIN, I _{OH} = MAX, V _{IN} = V _{IH} or V _{IL} per Truth Table	
V _{OL}	Output LOW Voltage		0.25	0.4	V	V _{CC} = V _{CC} MIN, V _{IN} = V _{IL} or V _{IH} per Truth Table	
			0.35	0.5	V		I _{OL} = 24 mA
I _{OZH}	Output Off Current HIGH			20	μA	V _{CC} = MAX, V _{OUT} = 2.4 V	
I _{OZL}	Output Off Current LOW			-20	μA	V _{CC} = MAX, V _{OUT} = 0.4 V	
I _{IH}	Input HIGH Current			20	μA	V _{CC} = MAX, V _{IN} = 2.7 V	
				0.1	mA	V _{CC} = MAX, V _{IN} = 7.0 V	
I _{IL}	Input LOW Current			-0.4	mA	V _{CC} = MAX, V _{IN} = 0.4 V	
I _{OS}	Short Circuit Current (Note 1)	-40		-225	mA	V _{CC} = MAX	
I _{CC}	Power Supply Current	LS125A		20	mA	V _{CC} = MAX	V _{IN} = 0 V, V _E = 4.5 V
		LS126A		22			V _{IN} = 0 V, V _E = 0 V

Note 1: Not more than one output should be shorted at a time, nor for more than 1 second.

AC CHARACTERISTICS (T_A = 25°C)

Symbol	Parameter		Limits			Unit	Test Conditions
			Min	Typ	Max		
t _{PLH}	Propagation Delay, Data to Output	LS125A		9.0	15	ns	Figure 2
t _{PLH}		LS126A		9.0	15		
t _{PHL}		LS125A		7.0	18		
t _{PHL}		LS126A		8.0	18		
t _{PZH}	Output Enable Time to HIGH Level	LS125A		12	20	ns	Figures 4, 5
		LS126A		16	25		
t _{PZL}	Output Enable Time to LOW Level	LS125A		15	25	ns	Figures 3, 5
		LS126A		21	35		
t _{PHZ}	Output Disable Time from HIGH Level	LS125A			20	ns	Figures 4, 5
		LS126A			25		
t _{PLZ}	Output Disable Time from LOW Level	LS125A			20	ns	Figures 3, 5
		LS126A			25		

SN74LS125A SN74LS126A

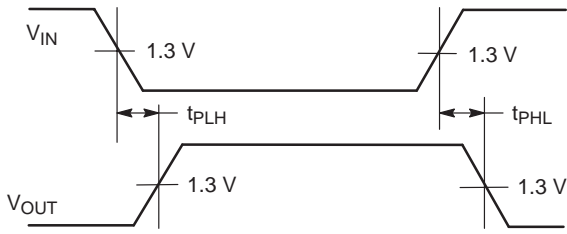

Figure 1.

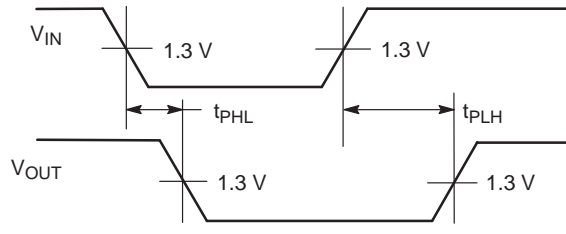

Figure 2.

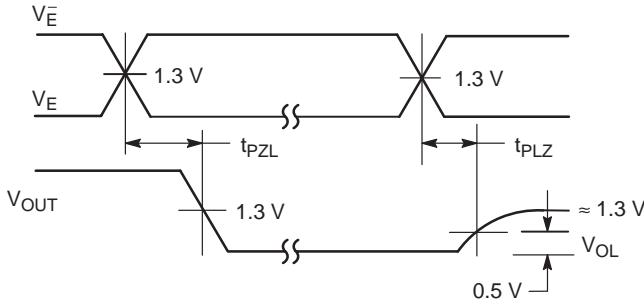

Figure 3.

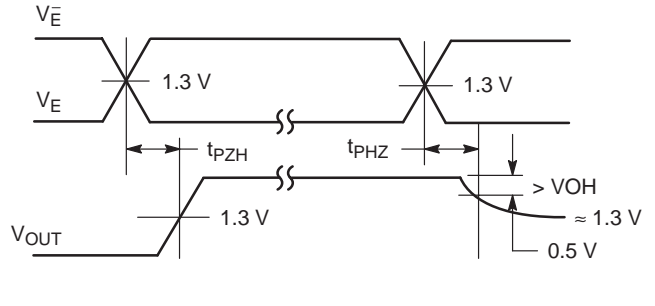

Figure 4.

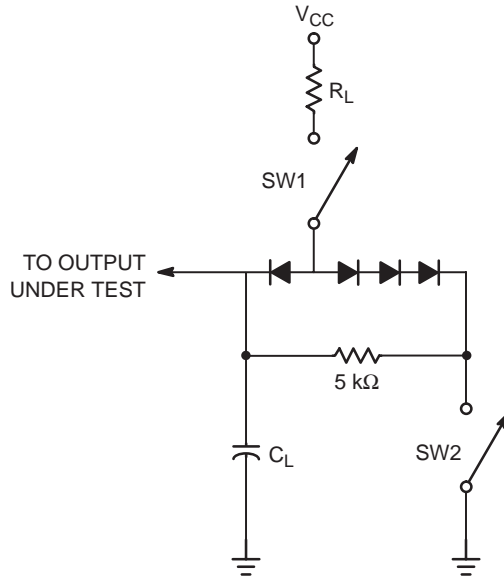

Figure 5.

SWITCH POSITIONS

SYMBOL	SW1	SW2
t_{PZH}	Open	Closed
t_{PZL}	Closed	Open
t_{PLZ}	Closed	Closed
t_{PHZ}	Closed	Closed