

# SN74LS139

## Dual 1-of-4 Decoder/ Demultiplexer

The LSTTL/MSI SN74LS139 is a high speed Dual 1-of-4 Decoder/Demultiplexer. The device has two independent decoders, each accepting two inputs and providing four mutually exclusive active LOW Outputs. Each decoder has an active LOW Enable input which can be used as a data input for a 4-output demultiplexer. Each half of the LS139 can be used as a function generator providing all four minterms of two variables. The LS139 is fabricated with the Schottky barrier diode process for high speed and is completely compatible with all ON Semiconductor TTL families.

- Schottky Process for High Speed
- Multifunction Capability
- Two Completely Independent 1-of-4 Decoders
- Active Low Mutually Exclusive Outputs
- Input Clamp Diodes Limit High Speed Termination Effects
- ESD > 3500 Volts

### GUARANTEED OPERATING RANGES

Symbol	Parameter	Min	Typ	Max	Unit
V <sub>CC</sub>	Supply Voltage	4.75	5.0	5.25	V
T <sub>A</sub>	Operating Ambient Temperature Range	0	25	70	°C
I <sub>OH</sub>	Output Current – High			-0.4	mA
I <sub>OL</sub>	Output Current – Low			8.0	mA



**ON Semiconductor**  
Formerly a Division of Motorola  
<http://onsemi.com>

**LOW  
POWER  
SCHOTTKY**

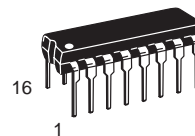

**PLASTIC  
N SUFFIX  
CASE 648**

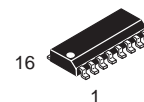

**SOIC  
D SUFFIX  
CASE 751B**

### ORDERING INFORMATION

Device	Package	Shipping
SN74LS139N	16 Pin DIP	2000 Units/Box
SN74LS139D	16 Pin	2500/Tape & Reel

# SN74LS139

## CONNECTION DIAGRAM DIP (TOP VIEW)

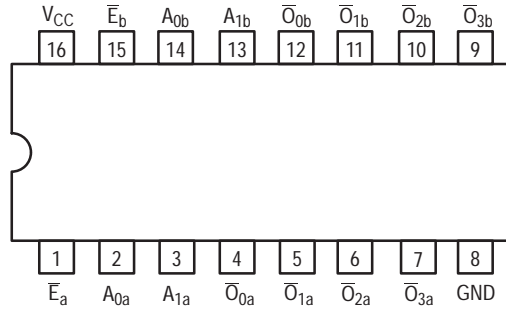

NOTE:  
The Flatpak version has the same pinouts (Connection Diagram) as the Dual In-Line Package.

PIN NAMES	LOADING (Note a)	
	HIGH	LOW
$A_0, A_1$ Address Inputs	0.5 U.L.	0.25 U.L.
$E$ Enable (Active LOW) Input	0.5 U.L.	0.25 U.L.
$\bar{O}_0 - \bar{O}_3$ Active LOW Outputs	10 U.L.	5 U.L.

### NOTES:

a) 1 TTL Unit Load (U.L.) = 40  $\mu$ A HIGH/1.6 mA LOW.

## LOGIC SYMBOL

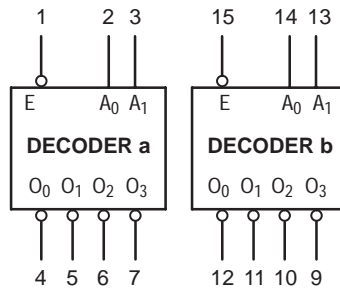

$V_{CC}$  = PIN 16  
GND = PIN 8

# SN74LS139

## LOGIC DIAGRAM

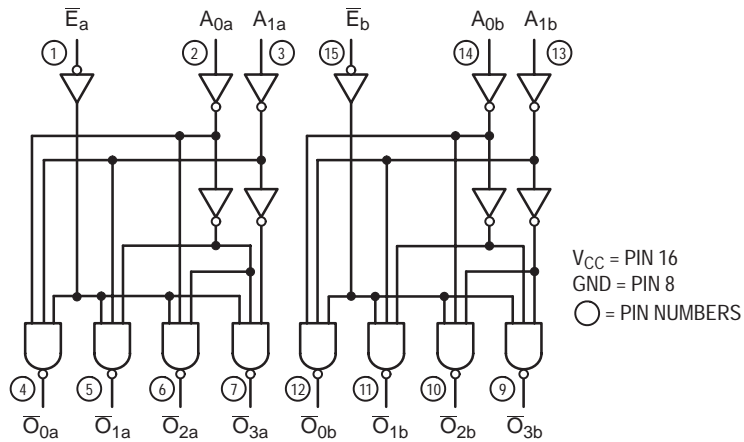

### FUNCTIONAL DESCRIPTION

The LS139 is a high speed dual 1-of-4 decoder/demultiplexer fabricated with the Schottky barrier diode process. The device has two independent decoders, each of which accept two binary weighted inputs ( $A_0$ ,  $A_1$ ) and provide four mutually exclusive active LOW outputs ( $\bar{O}_0$ – $\bar{O}_3$ ). Each decoder has an active LOW Enable ( $\bar{E}$ ). When E is HIGH all outputs are forced HIGH. The enable

can be used as the data input for a 4-output demultiplexer application.

Each half of the LS139 generates all four minterms of two variables. These four minterms are useful in some applications, replacing multiple gate functions as shown in Fig. a, and thereby reducing the number of packages required in a logic network.

### TRUTH TABLE

INPUTS			OUTPUTS			
$\bar{E}$	$A_0$	$A_1$	$\bar{O}_0$	$\bar{O}_1$	$\bar{O}_2$	$\bar{O}_3$
H	X	X	H	H	H	H
L	L	L	L	H	H	H
L	H	L	H	L	H	H
L	L	H	H	H	L	H
L	H	H	H	H	H	L

H = HIGH Voltage Level  
L = LOW Voltage Level  
X = Don't Care

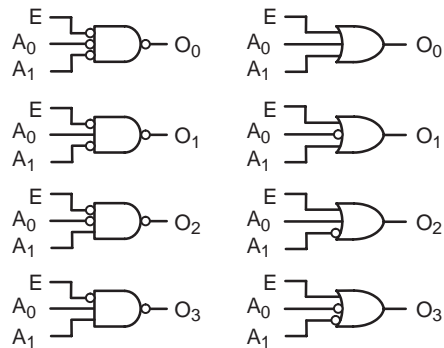

Figure a

# SN74LS139

## DC CHARACTERISTICS OVER OPERATING TEMPERATURE RANGE (unless otherwise specified)

Symbol	Parameter	Limits			Unit	Test Conditions
		Min	Typ	Max		
$V_{IH}$	Input HIGH Voltage	2.0			V	Guaranteed Input HIGH Voltage for All Inputs
$V_{IL}$	Input LOW Voltage			0.8	V	Guaranteed Input LOW Voltage for All Inputs
$V_{IK}$	Input Clamp Diode Voltage		-0.65	-1.5	V	$V_{CC} = \text{MIN}$ , $I_{IN} = -18 \text{ mA}$
$V_{OH}$	Output HIGH Voltage	2.7	3.5		V	$V_{CC} = \text{MIN}$ , $I_{OH} = \text{MAX}$ , $V_{IN} = V_{IH}$ or $V_{IL}$ per Truth Table
$V_{OL}$	Output LOW Voltage		0.25	0.4	V	$V_{CC} = V_{CC} \text{ MIN}$ , $V_{IN} = V_{IL}$ or $V_{IH}$ per Truth Table
			0.35	0.5	V	
$I_{IH}$	Input HIGH Current			20	$\mu\text{A}$	$V_{CC} = \text{MAX}$ , $V_{IN} = 2.7 \text{ V}$
				0.1	mA	$V_{CC} = \text{MAX}$ , $V_{IN} = 7.0 \text{ V}$
$I_{IL}$	Input LOW Current			-0.4	mA	$V_{CC} = \text{MAX}$ , $V_{IN} = 0.4 \text{ V}$
$I_{OS}$	Short Circuit Current (Note 1)	-20		-100	mA	$V_{CC} = \text{MAX}$
$I_{CC}$	Power Supply Current			11	mA	$V_{CC} = \text{MAX}$

Note 1: Not more than one output should be shorted at a time, nor for more than 1 second.

## AC CHARACTERISTICS ( $T_A = 25^\circ\text{C}$ )

Symbol	Parameter	Levels of Delay	Limits			Unit	Test Conditions
			Min	Typ	Max		
$t_{PLH}$ $t_{PHL}$	Propagation Delay Address to Output	2		13 22	20 33	ns	$V_{CC} = 5.0 \text{ V}$ $C_L = 15 \text{ pF}$
$t_{PLH}$ $t_{PHL}$	Propagation Delay Address to Output	3		18 25	29 38	ns	
$t_{PLH}$ $t_{PHL}$	Propagation Delay Enable to Output	2 2		16 21	24 32	ns	

## AC WAVEFORMS

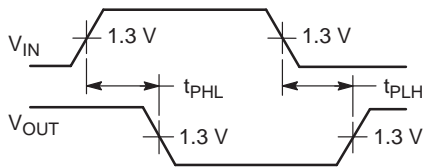

Figure 1.

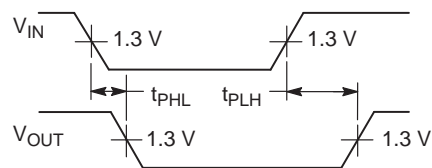

Figure 2.