

SN54LS224A, SN74LS224A 16 × 4 SYNCHRONOUS FIRST-IN, FIRST-OUT MEMORIES WITH 3-STATE OUTPUTS

SDLS023D – JANUARY 1991 – REVISED MARCH 2002

- Independent Synchronous Inputs and Outputs
- 16 Words by 4 Bits Each
- 3-State Outputs Drive Bus Lines Directly
- Data Rates up to 10 MHz
- Fall-Through Time 50 ns Typical
- Data Terminals Arranged for Printed Circuit Board Layout
- Expandable Using External Gating
- Packaged in Standard Plastic (N) and Ceramic (J) 300-mil DIPs, and Ceramic Chip Carriers (FK)

description

The SN54LS224A and SN74LS224A 64-bit, low-power Schottky memories are organized as 16 words by 4 bits each. They can be expanded in multiples of $15m + 1$ words or $4n$ bits, or both (where n is the number of packages in the vertical array and m is the number of packages in the horizontal array); however, some external gating is required. For longer words, the input-ready (IR) signals of the first-rank packages and output-ready (OR) signals of the last-rank packages must be ANDed for proper synchronization.

A first-in, first-out (FIFO) memory is a storage device that allows data to be written to and read from its array at independent data rates. These FIFOs are designed to process data at rates up to 10 MHz in a bit-parallel format, word by word.

The load clock (LDCK) normally is held low, and data is written into memory on the high-to-low transition of LDCK. The unload clock (UNCK) normally is held high, and data is read out on the low-to-high transition of UNCK. The memory is full when the number of words clocked in exceeds by 16 the number of words clocked out. When the memory is full, LDCK signals have no effect on the data residing in memory. When the memory is empty, UNCK signals have no effect.

Status of the FIFO memory is monitored by the IR and OR flags that indicate not-full and not-empty conditions. IR is high only when the memory is not full and LDCK is low. OR is high only when the memory is not empty and UNCK is high.

A low level on the clear ($\overline{\text{CLR}}$) input resets the internal stack-control pointers and also sets IR high and OR low to indicate that old data remaining at the data outputs is invalid. Data outputs are noninverting, with respect to the data inputs, and are at high impedance when the output-enable (OE) input is low. OE does not affect the IR and OR outputs.

The SN74LS224A is characterized for operation from 0°C to 70°C. The SN54LS224A is characterized over the full military temperature range of -55°C to 125°C.

SN54LS224A . . . J PACKAGE
SN74LS224A . . . N PACKAGE
(TOP VIEW)

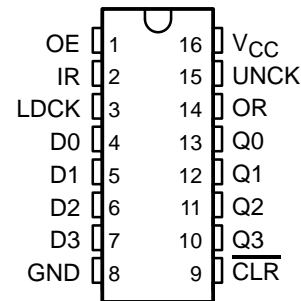

SN54LS224A . . . FK PACKAGE
(TOP VIEW)

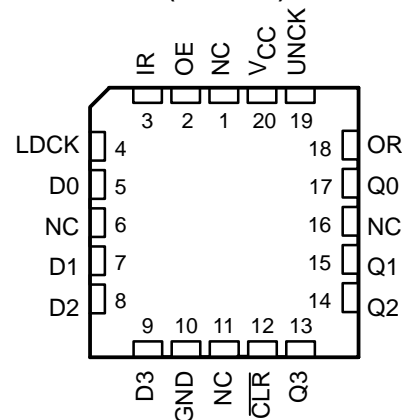

NC – No internal connection



Please be aware that an important notice concerning availability, standard warranty, and use in critical applications of Texas Instruments semiconductor products and disclaimers thereto appears at the end of this data sheet.

PRODUCTION DATA information is current as of publication date. Products conform to specifications per the terms of Texas Instruments standard warranty. Production processing does not necessarily include testing of all parameters.

**TEXAS
INSTRUMENTS**

POST OFFICE BOX 655303 • DALLAS, TEXAS 75265

Copyright © 2002, Texas Instruments Incorporated
On products compliant to MIL-PRF-38535, all parameters are tested unless otherwise noted. On all other products, production processing does not necessarily include testing of all parameters.

SN54LS224A, SN74LS224A 16 × 4 SYNCHRONOUS FIRST-IN, FIRST-OUT MEMORIES WITH 3-STATE OUTPUTS

SDLS023D – JANUARY 1991 – REVISED MARCH 2002

logic symbol†

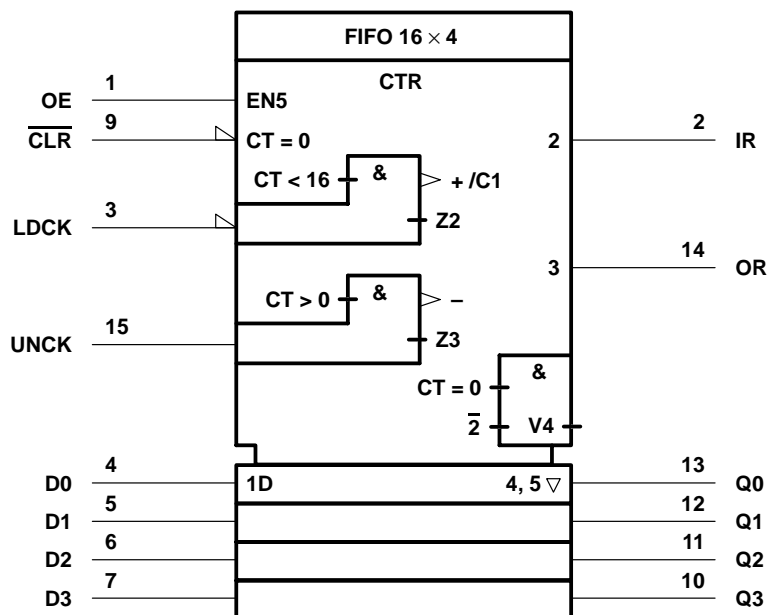

† This symbol is in accordance with ANSI/IEEE Standard 91-1984 and IEC Publication 617-12. This symbol is functionally accurate but does not show the details of implementation; for these details, see the logic diagram. The symbol represents the memory as if it were controlled by a single counter whose content is the number of words stored at the time. Output data is invalid when the counter content (CT) is 0. Pin numbers shown are for the J and N packages.

SN54LS224A, SN74LS224A

16 × 4 SYNCHRONOUS FIRST-IN, FIRST-OUT MEMORIES

WITH 3-STATE OUTPUTS

SDLS023D – JANUARY 1991 – REVISED MARCH 2002

logic diagram (positive logic)

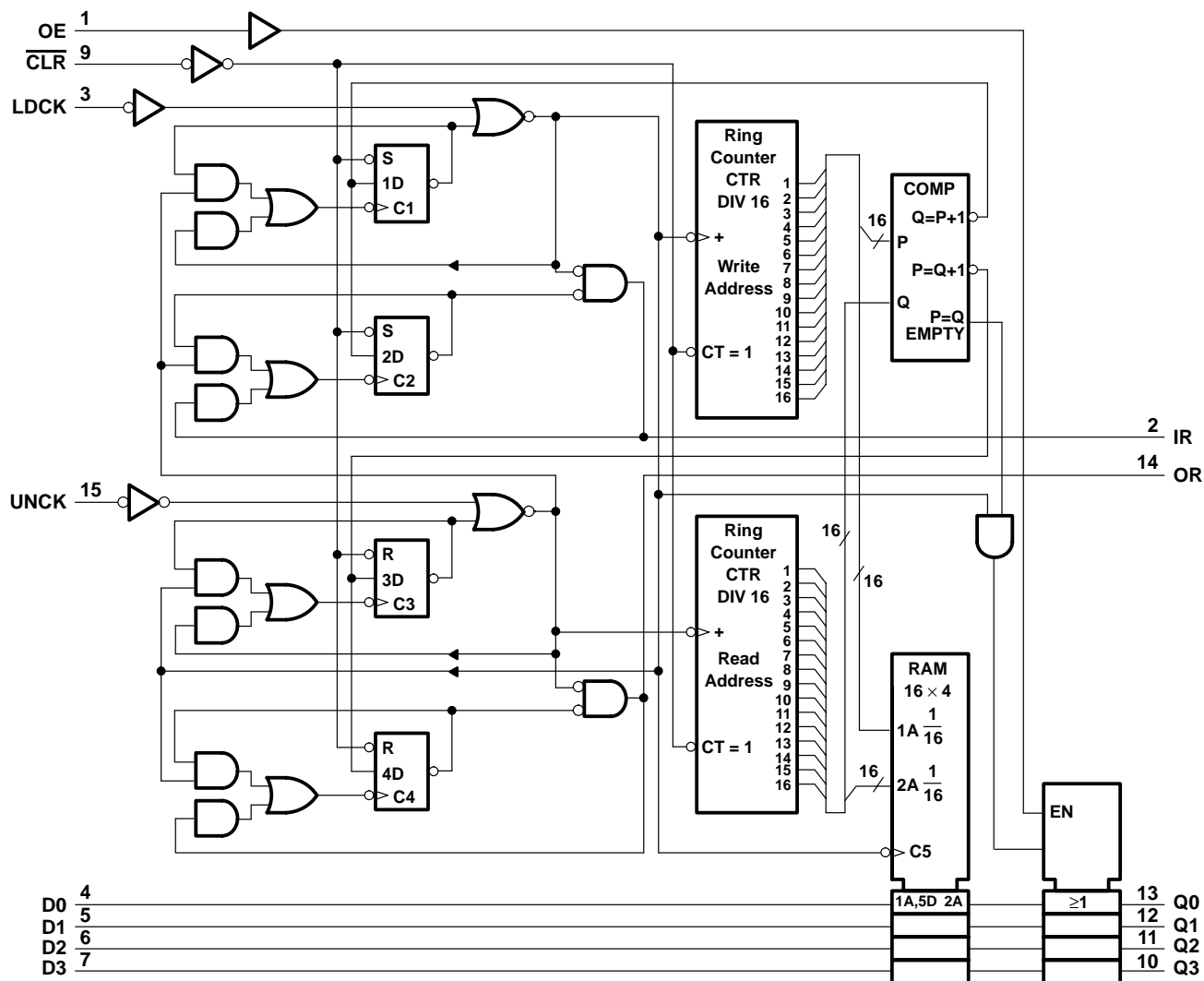

Pin numbers shown are for the J and N packages.

SN54LS224A, SN74LS224A

16 × 4 SYNCHRONOUS FIRST-IN, FIRST-OUT MEMORIES

WITH 3-STATE OUTPUTS

SDLS023D – JANUARY 1991 – REVISED MARCH 2002

schematics of inputs and outputs

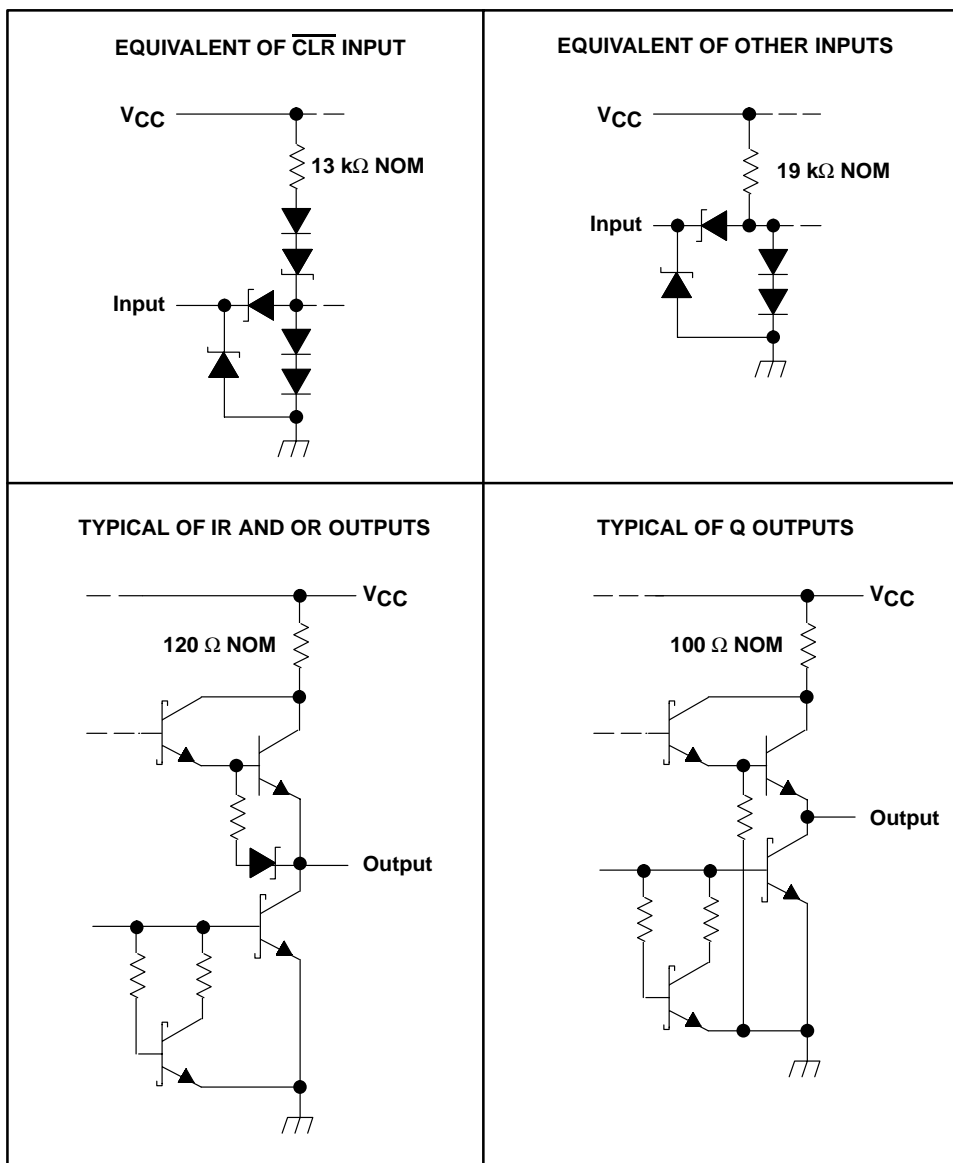

SN54LS224A, SN74LS224A
16 × 4 SYNCHRONOUS FIRST-IN, FIRST-OUT MEMORIES
WITH 3-STATE OUTPUTS

SDLS023D – JANUARY 1991 – REVISED MARCH 2002

timing diagram

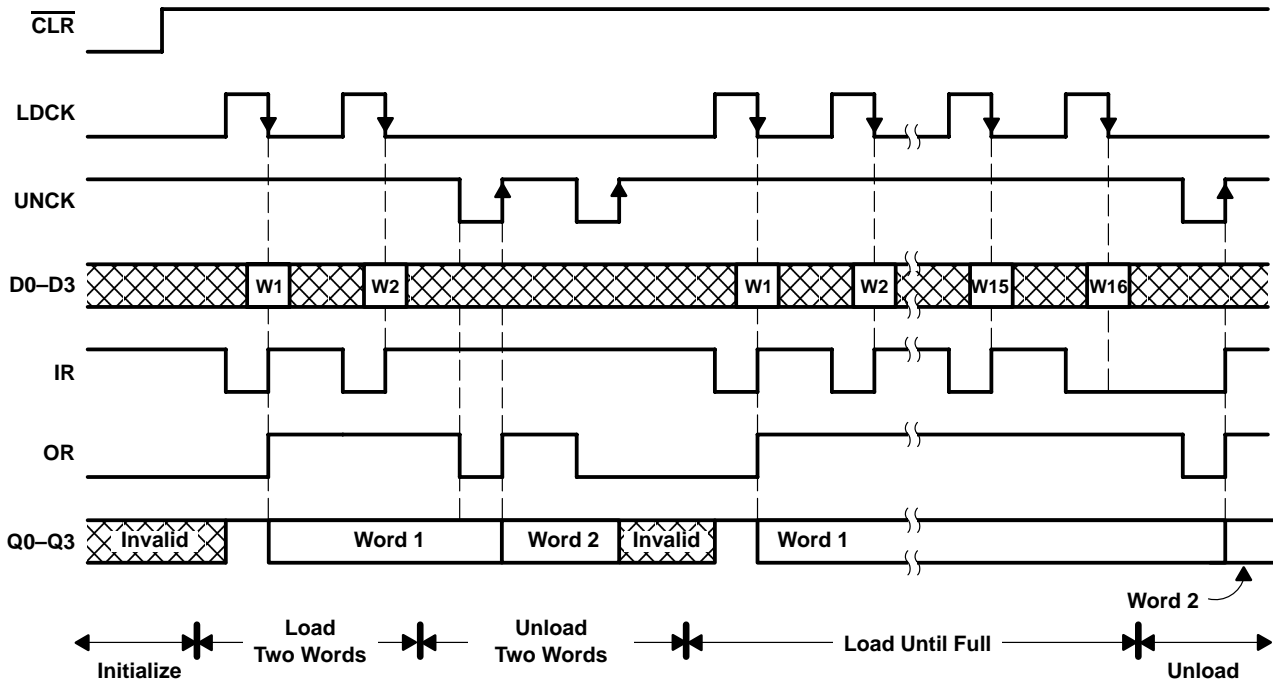

absolute maximum ratings over operating free-air temperature range (unless otherwise noted)†

Supply voltage range, V_{CC} (see Note 1)	-0.5 V to 7 V
Input voltage range, V_I	-0.5 V to 7 V
Off-state output voltage range, V_O	-0.5 V to 5.5 V
Package thermal impedance, θ_{JA} : N package (see Note 2)	67°C/W
	N package (see Note 3)	88°C/W
Storage temperature range, T_{stg}	-65°C to 150°C

† Stresses beyond those listed under "absolute maximum ratings" may cause permanent damage to the device. These are stress ratings only and functional operation of the device at these or any other conditions beyond those indicated under "recommended operating conditions" is not implied. Exposure to absolute-maximum-rated conditions for extended periods may affect device reliability.

- NOTES:
1. All voltage values are with respect to GND.
 2. The package thermal impedance is calculated in accordance with JESD 51-7.
 3. The package thermal impedance is calculated in accordance with JESD 51-3.

SN54LS224A, SN74LS224A

16 × 4 SYNCHRONOUS FIRST-IN, FIRST-OUT MEMORIES

WITH 3-STATE OUTPUTS

SDLS023D – JANUARY 1991 – REVISED MARCH 2002

recommended operating conditions (see Note 4)

		SN54LS224A			SN74LS224A			UNIT	
		MIN	NOM	MAX	MIN	NOM	MAX		
V _{CC}	Supply voltage	4.5	5	5.5	4.75	5	5.25	V	
V _{IH}	High-level input voltage	2			2			V	
V _{IL}	Low-level input voltage			0.7			0.8	V	
I _{OH}	High-level output current	Q outputs		-1			-2.6	mA	
		IR, OR		-0.4		-0.4			
I _{OL}	Low-level output current	Q outputs		12		24		mA	
		IR, OR		4		8			
T _A	Operating free-air temperature	-55		125		0		70	°C

NOTE 4: To ensure proper operation of this high-speed FIFO device, it is necessary to provide a clean signal to the LDCK and UNCK clock inputs. Any excessive noise or glitching on the clock inputs that violates the V_{IL}, V_{IH}, or minimum pulse-duration limits can cause a false clock or improper operation of the internal read and write pointers.

electrical characteristics over recommended operating free-air temperature range (unless otherwise noted)

PARAMETER		TEST CONDITIONS†		SN54LS224A			SN74LS224A			UNIT
				MIN	TYP‡	MAX	MIN	TYP‡	MAX	
V _{IK}		V _{CC} = MIN,	I _I = -18 mA	-1.5			-1.5			V
V _{OH}	Q outputs	V _{CC} = MIN	I _{OH} = -2.6 mA				2.4	3.4	V	
	IR, OR	V _{CC} = MIN,	I _{OH} = -0.4 mA	2.4	3.3					
V _{OL}	Q outputs	V _{CC} = MIN	I _{OL} = 12 mA	0.25	0.4	0.25	0.4	V		
			I _{OL} = 24 mA			0.35	0.5			
	IR, OR	V _{CC} = MIN	I _{OL} = 4 mA	0.25	0.4	0.25	0.4			
			I _{OL} = 8 mA			0.35	0.5			
I _{OZH}	Q outputs	V _{CC} = MAX,	V _O = 2.7 V	20			20			μA
I _{OZL}	Q outputs	V _{CC} = MAX,	V _O = 0.4 V	-20			-20			μA
I _I		V _{CC} = MAX,	V _I = 7 V	0.1			0.1			mA
I _{IH}		V _{CC} = MAX,	V _I = 2.7 V	20			20			μA
I _{IL}		V _{CC} = MAX,	V _I = 0.4 V	-0.4			-0.4			mA
I _{OS} §	Q outputs	V _{CC} = MAX		-30	-130	-30	-130	mA		
	IR, OR			-20	-100	-20	-100			
I _{CC}	V _{CC} = MAX		Outputs high	84	135	84	135	mA		
			Outputs low	87	155	87	155			
			Outputs disabled	89	155	89	155			

† For conditions shown as MIN or MAX, use the appropriate value specified under recommended operating conditions.

‡ All typical values are at V_{CC} = 5 V, T_A = 25°C.

§ Not more than one output should be shorted at a time, and duration of the short circuit should not exceed one second.



SN54LS224A, SN74LS224A 16 × 4 SYNCHRONOUS FIRST-IN, FIRST-OUT MEMORIES WITH 3-STATE OUTPUTS

SDLS023D – JANUARY 1991 – REVISED MARCH 2002

timing requirements over recommended operating conditions (see Note 4 and Figure 1)

		SN54LS224A		SN74LS224A		UNIT
		MIN	MAX	MIN	MAX	
t_w	Pulse duration	LDCK high	60	60	ns	
		LDCK low	15	15		
		UNCK low	30	30		
		UNCK high	30	30		
		CLR low	20	20		
t_{su}	Setup time	Data to LDCK↓	50	50	ns	
		LDCK↓ before UNCK↓	50	50		
		UNCK↑ before LDCK↑	50	50		
t_h	Hold time	Data from LDCK↓	0	10	ns	

NOTE 4: To ensure proper operation of this high-speed FIFO device, it is necessary to provide a clean signal to the LDCK and UNCK clock inputs. Any excessive noise or glitching on the clock inputs that violates the V_{IL} , V_{IH} , or minimum pulse-duration limits can cause a false clock or improper operation of the internal read and write pointers.

switching characteristics, $V_{CC} = 5\text{ V}$, $T_A = 25^\circ\text{C}$ (see Figure 1)

PARAMETER	FROM (INPUT)	TO (OUTPUT)	TEST CONDITIONS	MIN	TYP	MAX	UNIT
t_{PLH}	LDCK↓	IR	$R_L = 2\text{ k}\Omega$, $C_L = 15\text{ pF}$	25	40	ns	
t_{PHL}	LDCK↑			36	50		
t_{PLH}	LDCK↓	OR	$R_L = 2\text{ k}\Omega$, $C_L = 15\text{ pF}$	48	70	ns	
t_{PLH}	UNCK↑	OR	$R_L = 2\text{ k}\Omega$, $C_L = 15\text{ pF}$	29	45	ns	
t_{PHL}	UNCK↓			28	45		
t_{PLH}	UNCK↑	IR	$R_L = 2\text{ k}\Omega$, $C_L = 15\text{ pF}$	49	70	ns	
t_{PLH}	$\overline{\text{CLR}}\downarrow$	IR	$R_L = 2\text{ k}\Omega$, $C_L = 15\text{ pF}$	36	55	ns	
t_{PHL}		OR		25	40		
t_{PHL}	LDCK↓	Q	$R_L = 667\ \Omega$, $C_L = 45\text{ pF}$	34	50	ns	
t_{PLH}	UNCK↑	Q	$R_L = 667\ \Omega$, $C_L = 45\text{ pF}$	54	80	ns	
t_{PHL}				45	70		
t_{PZL}	OE↑	Q	$R_L = 667\ \Omega$, $C_L = 45\text{ pF}$	22	35	ns	
t_{PZH}				21	35		
t_{PLZ}	OE↓	Q	$R_L = 667\ \Omega$, $C_L = 5\text{ pF}$	16	30	ns	
t_{PHZ}				18	30		

SN54LS224A, SN74LS224A 16 × 4 SYNCHRONOUS FIRST-IN, FIRST-OUT MEMORIES WITH 3-STATE OUTPUTS

SDLS023D – JANUARY 1991 – REVISED MARCH 2002

PARAMETER MEASUREMENT INFORMATION

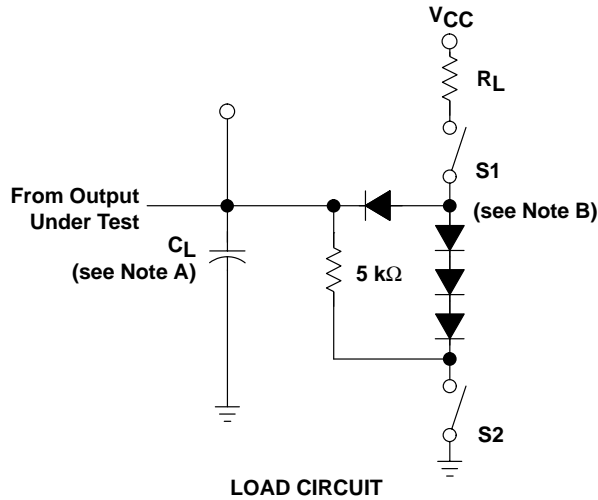

TEST	S1	S2
t_{PZL}	Closed	Open
t_{PZH}	Open	Closed
t_{PLZ}/t_{PHZ}	Closed	Closed
t_{PLH}/t_{PHL}	Closed	Closed

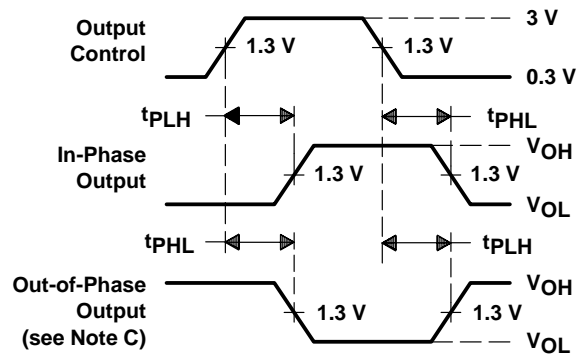
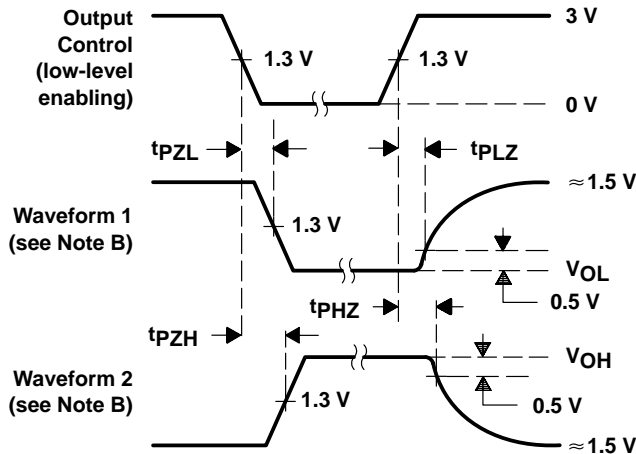
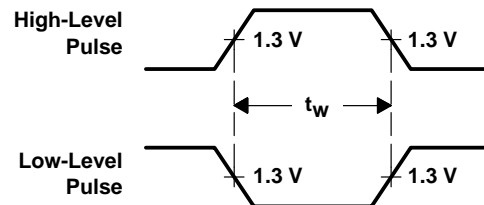
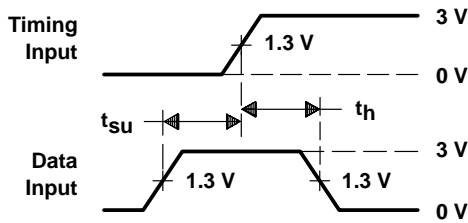

- NOTES: A. C_L includes probe and jig capacitance.
 B. Waveform 1 is for an output with internal conditions such that the output is low except when disabled by the output control. Waveform 2 is for an output with internal conditions such that the output is high except when disabled by the output control.
 C. All input pulses have the following characteristics: $PRR \leq 1$ MHz, $t_r < 15$ ns, $t_f < 6$ ns, $Z_O \approx 50 \Omega$.
 D. All diodes are 1N916 or 1N3064.
 E. The outputs are measured one at a time with one transition per measurement.

Figure 1. Load Circuits and Voltage Waveforms