

# SN74LS365A SN74LS367A SN74LS368A

## 3-State Hex Buffers

These devices are high speed hex buffers with 3-state outputs. They are organized as single 6-bit or 2-bit/4-bit, with inverting or non-inverting data (D) paths. The outputs are designed to drive 15 TTL Unit Loads or 60 Low Power Schottky loads when the Enable (E) is LOW.

When the Output Enable (E) is HIGH, the outputs are forced to a high impedance "off" state. If the outputs of the 3-state devices are tied together, all but one device must be in the high impedance state to avoid high currents that would exceed the maximum ratings. Designers should ensure that Output Enable signals to 3-state devices whose outputs are tied together are designed so there is no overlap.

### GUARANTEED OPERATING RANGES

Symbol	Parameter	Min	Typ	Max	Unit
$V_{CC}$	Supply Voltage	4.75	5.0	5.25	V
$T_A$	Operating Ambient Temperature Range	0	25	70	°C
$I_{OH}$	Output Current – High			-2.6	mA
$I_{OL}$	Output Current – Low			24	mA



**ON Semiconductor**  
Formerly a Division of Motorola  
<http://onsemi.com>

### LOW POWER SCHOTTKY

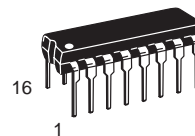

**PLASTIC  
N SUFFIX  
CASE 648**

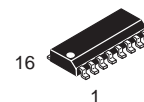

**SOIC  
D SUFFIX  
CASE 751B**

### ORDERING INFORMATION

Device	Package	Shipping
SN74LS365AN	16 Pin DIP	2000 Units/Box
SN74LS365AD	16 Pin	2500/Tape & Reel
SN74LS367AN	16 Pin DIP	2000 Units/Box
SN74LS367AD	16 Pin	2500/Tape & Reel
SN74LS368AN	16 Pin DIP	2000 Units/Box
SN74LS368AD	16 Pin	2500/Tape & Reel

SN74LS365A SN74LS367A SN74LS368A

SN74LS365A  
HEX 3-STATE BUFFER WITH  
COMMON 2-INPUT NOR ENABLE

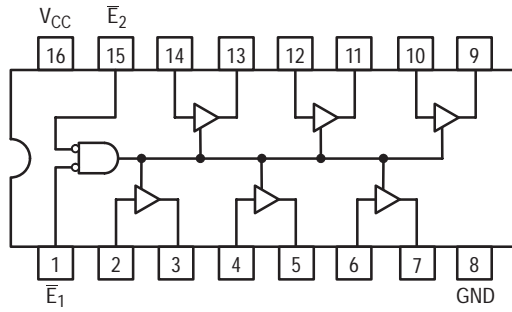

TRUTH TABLE

INPUTS			OUTPUT
$\bar{E}_1$	$\bar{E}_2$	D	
L	L	L	L
L	L	H	H
H	X	X	(Z)
X	H	X	(Z)

SN74LS367A  
HEX 3-STATE BUFFER  
SEPARATE 2-BIT AND 4-BIT SECTIONS

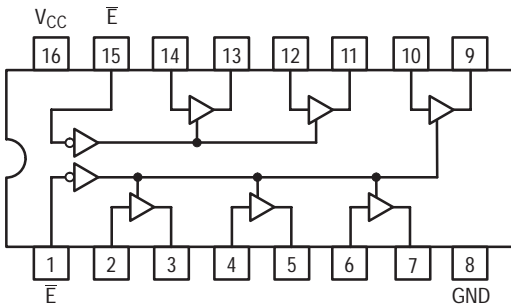

TRUTH TABLE

INPUTS		OUTPUT
E	D	
L	L	L
L	H	H
H	X	(Z)

SN74LS368A  
HEX 3-STATE INVERTER BUFFER  
SEPARATE 2-BIT AND 4-BIT SECTIONS

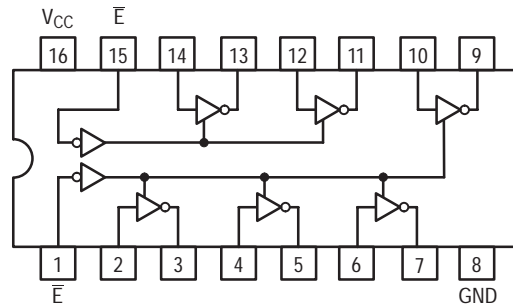

TRUTH TABLE

INPUTS		OUTPUT
E	D	
L	L	H
L	H	L
H	X	(Z)

# SN74LS365A SN74LS367A SN74LS368A

## DC CHARACTERISTICS OVER OPERATING TEMPERATURE RANGE (unless otherwise specified)

Symbol	Parameter	Limits			Unit	Test Conditions
		Min	Typ	Max		
V <sub>IH</sub>	Input HIGH Voltage	2.0			V	Guaranteed Input HIGH Voltage for All Inputs
V <sub>IL</sub>	Input LOW Voltage			0.8	V	Guaranteed Input LOW Voltage for All Inputs
V <sub>IK</sub>	Input Clamp Diode Voltage		-0.65	-1.5	V	V <sub>CC</sub> = MIN, I <sub>IN</sub> = -18 mA
V <sub>OH</sub>	Output HIGH Voltage	2.4	3.1		V	V <sub>CC</sub> = MIN, I <sub>OH</sub> = MAX, V <sub>IN</sub> = V <sub>IH</sub> or V <sub>IL</sub> per Truth Table
V <sub>OL</sub>	Output LOW Voltage		0.25	0.4	V	I <sub>OL</sub> = 12 mA V <sub>CC</sub> = V <sub>CC</sub> MIN, V <sub>IN</sub> = V <sub>IL</sub> or V <sub>IH</sub> per Truth Table
			0.35	0.5	V	
I <sub>OZH</sub>	Output Off Current HIGH			20	μA	V <sub>CC</sub> = MAX, V <sub>OUT</sub> = 2.7 V
I <sub>OZL</sub>	Output Off Current LOW			-20	μA	V <sub>CC</sub> = MAX, V <sub>OUT</sub> = 0.4 V
I <sub>IH</sub>	Input HIGH Current			20	μA	V <sub>CC</sub> = MAX, V <sub>IN</sub> = 2.7 V
				0.1	mA	V <sub>CC</sub> = MAX, V <sub>IN</sub> = 7.0 V
I <sub>IL</sub>	Input LOW Current E Inputs			-0.4	mA	V <sub>CC</sub> = MAX, V <sub>IN</sub> = 0.4 V
	D Inputs			-20	μA	V <sub>CC</sub> = MAX, V <sub>IN</sub> = 0.5 V Either $\bar{E}$ Input at 2.0 V
				-0.4	mA	V <sub>CC</sub> = MAX, V <sub>IN</sub> = 0.4 V Both $\bar{E}$ Inputs at 0.4 V
I <sub>OS</sub>	Short Circuit Current (Note 1)	-40		-225	mA	V <sub>CC</sub> = MAX
I <sub>CC</sub>	Power Supply Current LS365A, 367A			24	mA	V <sub>CC</sub> = MAX
	LS368A			21		

Note 1: Not more than one output should be shorted at a time, nor for more than 1 second.

## AC CHARACTERISTICS (T<sub>A</sub> = 25°C, V<sub>CC</sub> = 5.0 V)

Symbol	Parameter	Limits						Unit	Test Conditions
		LS365A/LS367A			LS366A/LS368A				
		Min	Typ	Max	Min	Typ	Max		
t <sub>PLH</sub> t <sub>PHL</sub>	Propagation Delay		10 9.0	16 22		7.0 12	15 18	ns	C <sub>L</sub> = 45 pF, R <sub>L</sub> = 667 Ω
t <sub>PZH</sub> t <sub>PZL</sub>	Output Enable Time		19 24	35 40		18 28	35 45	ns	
t <sub>PHZ</sub> t <sub>PLZ</sub>	Output Disable Time			30 35			32 35	ns	C <sub>L</sub> = 5.0 pF