

HD74LS49 • BCD-to-Seven Segment Decoder/Driver (with Open collector outputs)

The HD74LS49 features active-high outputs for driving lamp buffer. This circuit incorporates a direct blanking input. Segment identification and resultant displays are shown below. Display patterns for BCD input counts above 9 are unique symbols to authenticate input conditions. It contains an overriding blanking input (BI) which can be used to control the lamp intensity by pulsing or to inhibit the output. Inputs and outputs are entirely compatible for use with TTL or DTL logic outputs.

■ BLOCK DIAGRAM

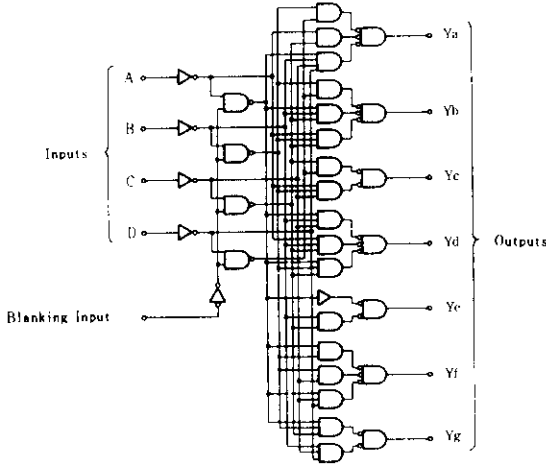

■ PIN ARRANGEMENT

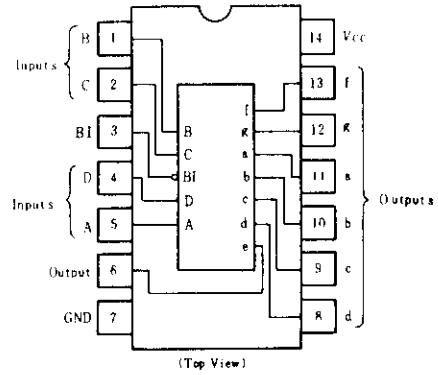

■ ABSOLUTE MAXIMUM RATINGS

Item	Symbol	Ratings	Unit
Supply voltage	V_{CC}	7.0	V
Input voltage	V_{IN}	7.0	V
Output current (off state)	$I_{O(off)}$	1	mA
Operating temperature range	T_{opr}	-20 ~ +75	°C
Storage temperature range	T_{stg}	65 ~ +150	°C

■ FUNCTION TABLE

Decimal or Function	Inputs					Outputs							Note
	D	C	B	A	BI	a	b	c	d	e	f	g	
0	L	L	L	L	H	H	H	H	H	H	H	L	
1	L	L	L	H	H	L	H	H	L	L	L	L	
2	L	L	H	L	H	H	H	L	H	H	L	H	
3	L	L	H	H	H	H	H	H	H	L	L	H	
4	L	H	L	L	H	L	H	H	L	L	H	H	
5	L	H	L	H	H	H	L	H	H	L	H	H	
6	L	H	H	L	H	L	L	H	H	H	H	H	
7	L	H	H	H	H	H	H	H	L	L	L	L	
8	H	L	L	L	H	H	H	H	H	H	H	H	
9	H	L	L	H	H	H	H	H	L	L	H	H	
10	H	L	H	L	H	L	L	L	H	H	L	H	
11	H	L	H	H	H	L	L	H	H	L	L	H	
12	H	H	L	L	H	L	H	L	L	L	H	H	
13	H	H	L	H	H	H	L	L	H	L	H	H	
14	H	H	H	L	H	L	L	L	H	H	H	H	
15	H	H	H	H	H	L	L	L	L	L	L	L	
BI	X	X	X	X	L	L	L	L	L	L	L	L	

H; high level, L; low level, X; irrelevant

- Notes: 1. The blanking input (BI) must be open or held at a high logic level when output functions 0 through 15 are desired.
 2. When a low logic level is applied directly to the blanking input (BI), all segment outputs are low regardless of the level of any other input.

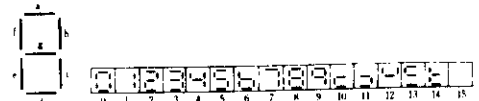

■ ELECTRICAL CHARACTERISTICS ($T_a = -20 \sim +75^\circ\text{C}$)

Item	Symbol	Test Conditions	min	typ*	max	Unit	
Input voltage	V_{IH}		2.0	—	—	V	
	V_{IL}		—	—	0.8	V	
Output current	I_{OH}	$V_{CC} = 4.75\text{V}$, $V_{IH} = 2\text{V}$, $V_{IL} = 0.8\text{V}$, $V_{OH} = 5.5\text{V}$	—	—	250	μA	
Output voltage	V_{OL}	$V_{CC} = 4.75\text{V}$, $V_{IH} = 2\text{V}$, $V_{IL} = 0.8\text{V}$	$I_{OL} = 4\text{mA}$	—	—	0.4	V
			$I_{OL} = 8\text{mA}$	—	—	0.5	
Input current	I_{IH}	$V_{CC} = 5.25\text{V}$, $V_I = 2.7\text{V}$	—	—	20	μA	
	I_{IL}	$V_{CC} = 5.25\text{V}$, $V_I = 0.4\text{V}$	—	—	-0.4	mA	
	I_i	$V_{CC} = 5.25\text{V}$, $V_I = 7\text{V}$	—	—	0.1	mA	
Supply current **	I_{CC}	$V_{CC} = 5.25\text{V}$	—	8	15	mA	
Input clamp voltage	V_{IK}	$V_{CC} = 4.75\text{V}$, $I_{IN} = -18\text{mA}$	—	—	-1.5	V	

* $V_{CC} = 5\text{V}$, $T_a = 25^\circ\text{C}$

** I_{CC} is measured with all outputs open and all inputs at 4.5V.

■ SWITCHING CHARACTERISTICS ($V_{CC} = 5\text{V}$, $T_a = 25^\circ\text{C}$)

Item	Symbol	Input	Test Conditions	min	typ	max	Unit
Propagation delay time	t_{PHL}	A	$C_L = 15\text{pF}$, $R_L = 2\text{k}\Omega$	—	—	100	ns
	t_{PLH}			—	—	100	
	t_{PHL}	BI	$C_L = 15\text{pF}$, $R_L = 6\text{k}\Omega$	—	—	100	ns
	t_{PLH}			—	—	100	

■ TESTING METHOD

1) Test Circuit

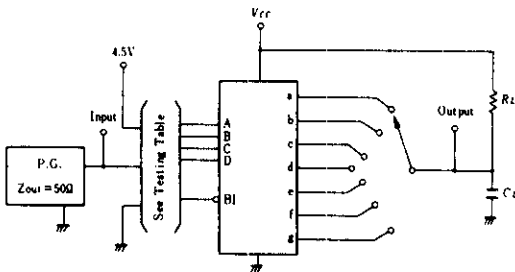

Waveform

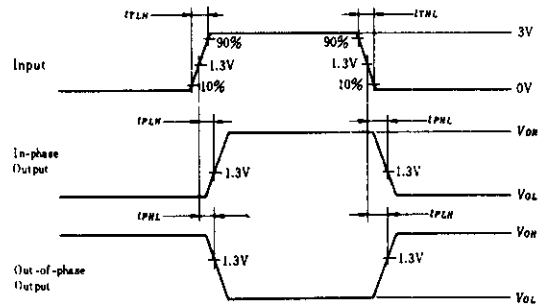

2) Testing Table

Item	Inputs					Outputs						
	BI	D	C	B	A	a	b	c	d	e	f	g
	4.5V	GND	GND	GND	IN	OUT	—	—	OUT	OUT	OUT	—
t_{PLH}	4.5V	GND	GND	4.5V	IN	—	—	OUT	—	OUT	—	—
t_{PHL}	4.5V	GND	4.5V	4.5V	IN	OUT	OUT	—	OUT	OUT	OUT	OUT
	IN	GND	GND	GND	GND	OUT	OUT	OUT	OUT	OUT	OUT	—

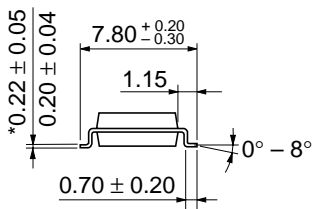
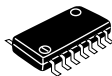
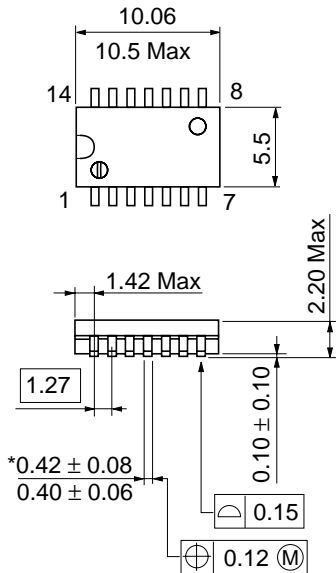

Hitachi Code	FP-14DA
JEDEC	—
EIAJ	Conforms
Weight (reference value)	0.23 g

*Dimension including the plating thickness
Base material dimension

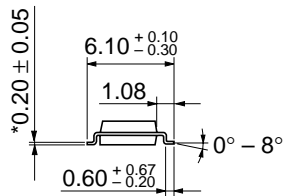
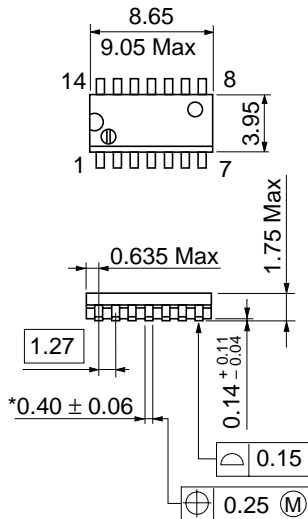

Hitachi Code	FP-14DN
JEDEC	Conforms
EIAJ	Conforms
Weight (reference value)	0.13 g