

SN74LS76A

Dual JK Flip-Flop with Set and Clear

The SN74LS76A offers individual J, K, Clock Pulse, Direct Set and Direct Clear inputs. These dual flip-flops are designed so that when the clock goes HIGH, the inputs are enabled and data will be accepted. The Logic Level of the J and K inputs will perform according to the Truth Table as long as minimum set-up times are observed. Input data is transferred to the outputs on the HIGH-to-LOW clock transitions.

MODE SELECT – TRUTH TABLE

OPERATING MODE	INPUTS				OUTPUTS	
	\bar{S}_D	\bar{C}_D	J	K	Q	\bar{Q}
Set	L	H	X	X	H	L
Reset (Clear)	H	L	X	X	L	H
*Undetermined	L	L	X	X	H	H
Toggle	H	H	h	h	\bar{q}	q
Load "0" (Reset)	H	H	l	h	L	H
Load "1" (Set)	H	H	h	l	H	L
Hold	H	H	l	l	q	\bar{q}

* Both outputs will be HIGH while both \bar{S}_D and \bar{C}_D are LOW, but the output states are unpredictable if \bar{S}_D and \bar{C}_D go HIGH simultaneously.

H, h = HIGH Voltage Level

L, l = LOW Voltage Level

X = Immaterial

l, h (q) = Lower case letters indicate the state of the referenced input (or output) one setup time prior to the HIGH-to-LOW clock transition



ON Semiconductor
Formerly a Division of Motorola
<http://onsemi.com>

**LOW
POWER
SCHOTTKY**

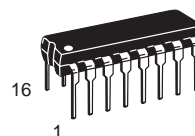

**PLASTIC
N SUFFIX
CASE 648**

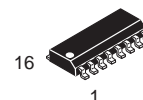

**SOIC
D SUFFIX
CASE 751B**

GUARANTEED OPERATING RANGES

Symbol	Parameter	Min	Typ	Max	Unit
V_{CC}	Supply Voltage	4.75	5.0	5.25	V
T_A	Operating Ambient Temperature Range	0	25	70	°C
I_{OH}	Output Current – High			-0.4	mA
I_{OL}	Output Current – Low			8.0	mA

ORDERING INFORMATION

Device	Package	Shipping
SN74LS76AN	16 Pin DIP	2000 Units/Box
SN74LS76AD	16 Pin	2500/Tape & Reel

SN74LS76A

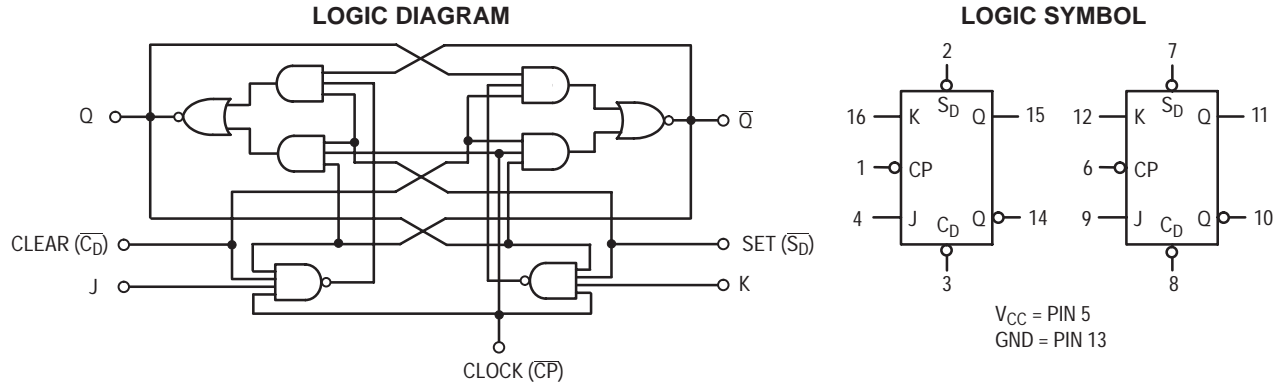

DC CHARACTERISTICS OVER OPERATING TEMPERATURE RANGE (unless otherwise specified)

Symbol	Parameter	Limits			Unit	Test Conditions
		Min	Typ	Max		
V_{IH}	Input HIGH Voltage	2.0			V	Guaranteed Input HIGH Voltage for All Inputs
V_{IL}	Input LOW Voltage			0.8	V	Guaranteed Input LOW Voltage for All Inputs
V_{IK}	Input Clamp Diode Voltage		-0.65	-1.5	V	$V_{CC} = \text{MIN}$, $I_{IN} = -18 \text{ mA}$
V_{OH}	Output HIGH Voltage	2.7	3.5		V	$V_{CC} = \text{MIN}$, $I_{OH} = \text{MAX}$, $V_{IN} = V_{IH}$ or V_{IL} per Truth Table
V_{OL}	Output LOW Voltage		0.25	0.4	V	$V_{CC} = V_{CC} \text{ MIN}$, $V_{IN} = V_{IL}$ or V_{IH} per Truth Table
			0.35	0.5	V	
I_{IH}	Input HIGH Current	J, K Clear Clock		20 60 80	μA	$V_{CC} = \text{MAX}$, $V_{IN} = 2.7 \text{ V}$
		J, K Clear Clock		0.1 0.3 0.4	mA	
I_{IL}	Input LOW Current	J, K Clear, Clock		-0.4 -0.8	mA	$V_{CC} = \text{MAX}$, $V_{IN} = 0.4 \text{ V}$
I_{OS}	Short Circuit Current (Note 1)		-20	-100	mA	$V_{CC} = \text{MAX}$
I_{CC}	Power Supply Current			6.0	mA	$V_{CC} = \text{MAX}$

Note 1: Not more than one output should be shorted at a time, nor for more than 1 second.

AC CHARACTERISTICS ($T_A = 25^\circ\text{C}$, $V_{CC} = 5.0 \text{ V}$)

Symbol	Parameter	Limits			Unit	Test Conditions
		Min	Typ	Max		
f_{MAX}	Maximum Clock Frequency	30	45		MHz	$V_{CC} = 5.0 \text{ V}$ $C_L = 15 \text{ pF}$
t_{PLH} t_{PHL}	Clock, Clear, Set to Output		15	20	ns	
			15	20	ns	

AC SETUP REQUIREMENTS ($T_A = 25^\circ\text{C}$)

Symbol	Parameter	Limits			Unit	Test Conditions
		Min	Typ	Max		
t_W	Clock Pulse Width High	20			ns	$V_{CC} = 5.0 \text{ V}$
t_W	Clear Set Pulse Width	25			ns	
t_s	Setup Time	20			ns	
t_h	Hold Time	0			ns	